

KENWOOD

430MHz ALL MODE TRANSCEIVER

TR-851A

TR-851E

144MHz ALL MODE TRANSCEIVER

TR-751A

TR-751E

INSTRUCTION MANUAL

KENWOOD CORPORATION

Thank you for purchasing our latest transceiver. This unit has been carefully engineered and manufactured to rigid quality standards, and should give you satisfactory and dependable operation for many years.

IMPORTANT:

Please read this instruction manual carefully before placing your transceiver in service.

This Instruction Manual covers the TR-851A/851E/751A/751E.

When there are differences in operation separate instructions will be given for each model. Illustrations show the TR-751A.

The following explicit definitions apply in this manual:

Note: If disregarded, inconvenience only, no risk of equipment damage or personal injury.

Caution: Equipment damage may occur, but not personal injury.

CONTENTS

1. BEFORE OPERATION.....	4	5-2. SERVICE.....	33
2. SPECIFICATIONS AND ACCESSORIES.....	5	5-3. CLEANING.....	33
2-1. SPECIFICATIONS.....	5	5-4. IN CASE OF DIFFICULTY.....	33
2-2. ACCESSORIES.....	6	5-5. MICROPROCESSOR BACK-UP LITHIUM BATTERY REPLACEMENT.....	34
3. INSTALLATION AND CONNECTION.....	7	5-6. ORDERING SPARE PARTS.....	34
3-1. INSTALLATION.....	7	5-7. ADJUSTMENTS.....	35
3-2. CONNECTION.....	8	6. BLOCK DIAGRAM AND CIRCUIT DIAGRAM.....	37
4. OPERATION.....	10	6-1. BLOCK DIAGRAM.....	37
4-1. CONTROLS AND THEIR FUNCTIONS.....	10	6-2. CIRCUIT DIAGRAM.....	39
4-2. RECEPTION.....	15	7. OPTIONAL ACCESSORIES.....	43
4-3. TRANSMISSION.....	18	7-1. TU-7 TONE UNIT.....	43
4-4. MEMORY.....	18	7-2. MU-1 MODEM UNIT.....	43
4-5. SCAN.....	21	7-3. TU-7 TONE UNIT AND MU-1 MODEM UNIT.....	43
4-6. REPEATER.....	22	7-4. VS-1 VOICE SYNTHESIZER UNIT.....	43
4-7. DCL (Digital Channel Link) SYSTEM.....	24	7-5. OTHER ACCESSORIES.....	44
4-8. VOICE SYNTHESIZER.....	31	8. REFERENCE.....	46
4-9. MICROPHONE UP/DWN SWITCH.....	32	8-1. ANTENNA.....	46
5. MAINTENANCE AND ADJUSTMENT.....	33	8-2. MOBILE INSTALLATION.....	47
5-1. GENERAL INFORMATION.....	33		

1. BEFORE OPERATION

Safety precautions

Never remove the case unless specified in this Instruction Manual. If the internal parts are touched, accidentally, a serious electric shock might occur.



Never touch internal parts.

If a metal object, such as a hair pin or a needle, comes into contact with the power socket on the rear panel, a dangerous electric shock may result. For families with children, never permit children to put anything, especially metal, inside this unit.



Touching the power plug when your hands are wet may result in a serious electric shock.



Never touch with wet hands.

Never pull, bend or extend the power cord. This could damage the power cord, resulting in a broken cord or short-circuit.



Always grasp the plug.

In case of abnormal smell

If an abnormal smell or smoke is detected, immediately turn the power OFF and pull out the power cord. Contact your dealer or nearest Service Station.



Notes on installation

Do not place the unit in a place which is exposed to direct sunlight, near a heating appliance, etc.



Do not store or use the unit in a dusty location or in a moist atmosphere. Select a location where air is well ventilated.



To maintain good ventilation, do not put records or a tablecloth on the unit. Place the unit at least 10 cm away from the walls.



Choose a location that is relatively free from vibration.



The unit may not function properly if used at extremely low, or freezing temperatures.



Cleaning

Do not use volatile solvents such as alcohol, paint thinner, gasoline, benzine, etc. to clean the cabinet. Use a silicone cloth or a clean dry cloth.



Silicone cloth Thinner Benzine

2. SPECIFICATIONS AND ACCESSORIES

2-1. SPECIFICATIONS

Specification		Model	TR-851A TR-851E	TR-751A	TR-751E	
General	Frequency range		430 to 440 MHz	144 to 148 MHz	144 to 146 MHz	
	Mode		USB/LSB (J3E), CW (A1A), FM (F3E, F2D for the control signal of the DCL system)			
	Antenna impedance		50 ohms			
	Power requirement		13.8 VDC \pm 15%			
	Grounding		Negative			
	Current drain	Receive mode with no input signal		0.8 A		
		Transmit mode (Max.)		7.5A	6A	
	Frequency stability (-20°C to +60°C)			Better than $\pm 20 \times 10^{-4}$	Better than $\pm 15 \times 10^{-4}$	
	Operating temperature			-20°C to +60°C (-4°F to +140°F)		
	Dimensions (W x H x D) (Projections included)			180 x 63 x 233 mm	180 x 63 x 213 mm	
Weight			2.5 kg (5.5 lbs)	2.2 kg (4.8 lbs)		
Transmitter	Output power *	HI	25 W			
		LOW	5 W (Adjustable up to out 25 W)			
	Modulation	USB/LSB		Balanced modulation		
		FM		Reactance modulation		
	Spurious radiation			Less than -60 dB		
	Carrier suppression (SSB)			More than 40 dB		
	Unwanted sideband suppression (SSB)			More than 40 dB		
	Maximum frequency deviation (FM)			\pm 5 kHz		
	Audio distortion (FM, at 60% modulation)			Less than 3% (300 to 3000 Hz)		
	Microphone impedance			500 to 600 ohms		
Receiver	Circuitry	USB/LSB/CW	Double conversion superheterodyne	Single conversion superheterodyne		
		FM	Tripple conversion superheterodyne	Double conversion superheterodyne		
	Intermediate frequency		41.415 MHz/ 10.695 MHz/ 455 kHz (FM only)	10.695 MHz/455 kHz (FM only)		
	Sensitivity	USB/LSB/CW (10 dB S + N/N)		Less than 0.11 μ V	Less than 0.13 μ V	
		FM (12 dB SINAD)		Less than 0.18 μ V	Less than 0.2 μ V	
	Selectivity	USB/LSB/CW	-6 dB		More than 2.2 kHz	
			-60 dB		Less than 4.8 kHz	
		FM	-6 dB		More than 12 kHz	
			-60 dB		Less than 24 kHz	
	Spurious response			Better than 60 dB	Better than 70 dB (Except fd-IF/2)	
RIT variable range				More than \pm 1.2 kHz		
Squelch sensitivity				Less than 0.1 μ V		
Output				More than 2 W across 8 ohms load (5% distortion)		
External speaker impedance				8 ohms		
DCL control	Code			NRZ equal-length code		
	Modulation			MSK modulation		
	Frequency deviation			\pm 3.5 kHz (Reference)		
	Mark frequency and deviation			1200 Hz, $\pm 2 \times 10^{-4}$		
	Space frequency and deviation			1800 Hz, $\pm 2 \times 10^{-4}$		
	Code transmission speed and deviation			1200 bits/second, $\pm 2 \times 10^{-4}$		

Notes:

1. Circuit and ratings are subject to change without notice due to advancements in technology.

2. * Recommended duty cycle

1 minute : Transmission

3 minutes: Reception

2-2. ACCESSORIES

Unpack your transceiver carefully and confirm that it is supplied with the following accessories.

Dynamic microphone (TR-751A U.S.A. version only)	(T91-0359-05)	1 ea.
Dynamic microphone (Except TR-751A U.S.A. version)	(T91-0357-15)	1 ea.
Hook (TR-851A U.S.A. version only)	(J19-1346-04)	1 ea.
Hook (TR-751A U.S.A. version only)	(J20-0319-24)	1 ea.
Tapping screw (TR-851A U.S.A. version only)	(N09-0633-05)	2 ea.
Tapping screw (TR-751A U.S.A. version only)	(N46-3010-46)	2 ea.
Mobile mounting kit		
Bracket	(A13-0668-04)	1 ea.
Bracket ass'y (Right)	(A13-0666-12)	1 ea.
Bracket ass'y (Left)	(A13-0667-12)	1 ea.
Cushion	(G13-0823-04)	4 ea.
Allen bolt (Black)	(N99-0304-04)	4 ea.
Hex socket screw	(N09-0008-04)	4 ea.
Flange nut	(N14-0510-04)	4 ea.
Flat washer (Black)	(N15-1040-45)	4 ea.
Flat washer	(N15-1060-46)	4 ea.
Spring washer	(N16-0060-46)	4 ea.
Tapping screw	(N09-0632-05)	4 ea.
Hex wrench	(W01-0401-05)	1 ea.
DC power cable	(E30-2053-05)	1 ea.
4-pin plug	(E09-0471-05)	1 ea.
Spare fuse (8 A) for TR-851A/851E	(F05-8021-05)	1 ea.
Spare fuse (7 A) for TR-751A/751E	(F05-7025-05)	1 ea.
Foot	(J02-0439-05)	4 ea.
Instruction manual	(B50-8111-00)	1 copy

After unpacking

Shipping container:

Save the boxes and packing in the event your unit needs to be transported for remote operation, maintenance, or service.

3. INSTALLATION AND CONNECTION

3-1. INSTALLATION

3-1-1. Precautions

1. Avoid direct sunlight, and select a dry, well ventilated location.
2. Since the heat sink is on the rear panel, avoid placing the equipment with the bottom and rear sides close to a wall or desk.
3. When installing the equipment in an automobile, ensure adequate ventilation. Install the equipment in a location where the rear does not make direct contact with the seat, and is not directly exposed to vibration.
4. Avoid installing the equipment in front of the car heater air outlet.

3-1-2. Power supply

The standard operating voltage of these transceivers is 13.8 V. The current is 7.5 A with the TR-851A/851E and 6 A with the TR-751A/751E. Do not use a power supply (either fixed or mobile) that provides over 16 V with the POWER switch of the transceiver turned off.

Operation under such conditions will void the warranty. Also, do not use a power supply that does not supply at least 12 V in transmit or receive. Use of such supply may cause the performance of the transceiver to suffer.

3-1-3. Foot installation

Attach the feet (4 pcs.) using the following procedures.

1. Place the radio with the bottom up.
2. Place each foot on the bottom cover so that the hole in the feet line up with the holes in the bottom cover.
3. Insert a rivet with pin into the hole of each foot. (Make sure the pin is not inserted too far or the rivet will not go in.)
4. Push the pin down securely to complete the installation.

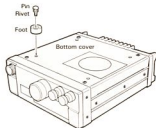

3-1-4. Mounting bracket

- A. Secure the transceiver under the dashboard using the supplied mounting bracket. Install the bracket as shown below. Do not install backwards.

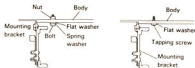

B. Installing the transceiver

Note:

Make sure that the transceiver will not slip out of place while operating the vehicle.

Follow the steps below:

1. Lift the lever.
2. Carefully slide the transceiver into the mounting bracket.

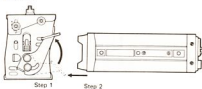

3. The angle of the bracket may be adjusted to any of 5 possible viewing angles by loosening the 4 allen bolts at the top of the bracket using the hex wrench provided.

After the desired angle has been selected tighten the 4 bolts.

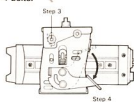

4. Press the lever down to secure the transceiver.
5. By installing a lock thru the keyhole on the side of the mounting bracket, the lever can be locked and the transceiver secured.



3-2. CONNECTION

3-2-1. Precautions

1. Before connecting and disconnecting the power connector, be sure to turn off the power switches of the transceiver and the DC power supply.

2. Observe polarity of the cable. The transceiver operates on 13.8 VDC, negative ground. Battery polarity must be correct. The power cable is color coded:

Red - + (Positive) polarity
Black - - (Negative) polarity

3-2-2. Fixed station

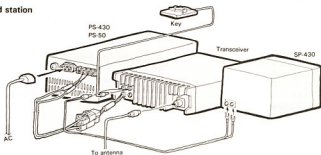

3-2-3. Mobile

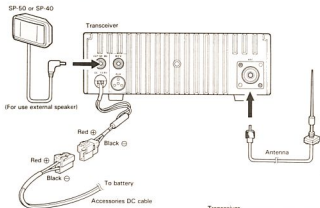

A. Battery connection

Connect the supplied power cable with fuse directly to the battery terminals. Connecting to the cigarette lighter socket can cause a poor connection, and excessive voltage drop.

Caution:

1. When connecting or disconnecting the power cable to or from the power connector, be sure that the power switch is always in the "OFF" position.
2. Disconnect the transceiver before jump-starting or before charging the battery.

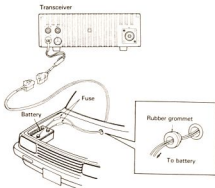

- When installing the transceiver in a vehicle, consider ease of operation and safety when selecting the installation location.

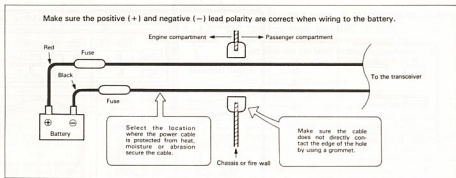

Notes:

- Before installing the power cable, be sure to remove the negative lead from the battery for safety.
- After installation and wiring, be sure to double check for correct installation before reconnecting the negative lead to the battery terminal.
- If the fuse opens, be sure to check that each conductor has not been damaged by short-circuiting, etc.
Then replace with a new fuse of the same rating.
- After completing the wiring, wrap the fuse holder with tape to protect against moisture.
- Do not remove the fuse even if the power cable is too long.

- If the wiring hole in the fire wall or chassis is too small, disassemble the fuse holder to thread the wire through the hole.



B. Ignition noise

This transceiver is designed to suppress ignition noise; however, if excessive noise is present, it may be necessary to use suppressor spark plugs (with resistors), or an external noise filter such as the PG-3B.

Note:

20 A fuse is used in negative (ground) line for additional protection.

3-2-4. Antenna

The antenna impedance is 50 ohms, do not use an antenna with other impedance ratings. Securely attach the antenna.

3-2-5. Key

As shown below, plug the key or electronic keyer into the KEY jack on the back panel. If the plug does not fit, use a commercially available conversion plug or wire the supplied 3.5 mm dia. plug as shown below.

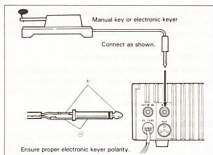

4. OPERATION

4-1. CONTROLS AND THEIR FUNCTIONS

4-1-1. Front panel

(With the TR-851E/751E)

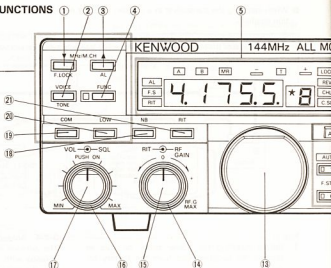
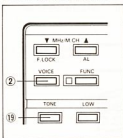

Note:

All segments on the Display Panel and Indicators are shown on for this explanation.

① ③ Up/Down (▼ MHz/M.CH ▲) keys

Use these keys to step frequencies [in the VFO A or VFO B mode] and Memory Channels [in the MR (Memory Recall) mode] UP or DOWN.

Note:

When the FUNC (Function) indicator is ON, the Down (▼ MHz) key functions as the F.LOCK (Frequency Lock) and the Up (M.CH ▲) key as the AL (Alert) key.

F.LOCK (Frequency Lock) key

Disables the TUNING knob, keys, and switches and locks the selected frequency and other settings. This function is active when the FUNC is ON and F.LOCK key is pressed.

AL (Alert) key

This switch is used to check the priority channel (M.CH1). When this switch is depressed M.CH1 will be checked at about 6-second intervals. This function is active, when the FUNC is ON and the AL key is pressed.

② VOICE key

Press this key to activate the optional voice synthesizer unit VS-1.

TONE key (TR-851A/751A only)

Activates the optional subaudible tone encoder (TU-7) when it is installed.

This function is active when the FUNC is ON and TONE key is pressed.

④ FUNC (Function) key

Pressing this key changes the functions of the Up/Down (▼ MHz/M.CH ▲) keys to the F.LOCK and AL keys and the VOICE key to the TONE key (TR-851A/751A only). FUNC indicator is ON when the FUNC key is in the ON position. Each time this key is pressed, the FUNC indicator alternates.

⑤ Display panel

The large LCD displays operational information such as transmit/receive frequencies and memory channel informations. (See page 12.)

⑥ S & RF meter

This meter operates as the S meter during reception to indicate signal strength and operates as the RF meter during transmission to indicate relative transmit power output.

This meter is set to point approximately to "B" in the high power mode.

Note:

The RF meter is calibrated with a 50-ohm dummy load; the meter readings will differ when the antenna's SWR is high.

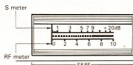

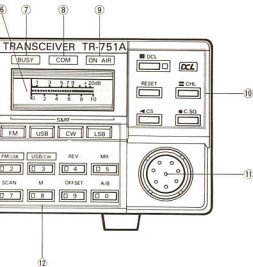

7 BUSY indicator

The BUSY indicator lights when the squelch circuit opens in the receive state. (It allows the operator to obtain a visual indication of station activity.) When the SQL control is turned fully counterclockwise, this indicator is lit.

8 COM (Common channel) indicator (TR-/851A/751A only)

This indicator is ON in the COM mode.

9 ON AIR indicator

The ON AIR indicator lights during transmit.

10 DCL system keyboard

These keys are used to operate the DCL system when the optional MU-1 modem unit is installed. (See pages 25 and 43.)

11 Microphone jack

Plug the standard or optional microphone into this jack.

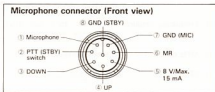

12 Mode/Numeric keypad

(See page 13)

13 TUNING knob

Turn the knob clockwise or counterclockwise to tune to the desired transmit/receive frequency. You can also use the knob to select tone frequencies and, in the DCL operation, digital codes.

14 RF GAIN control

Use the RF GAIN control to adjust the gain of the receiver high-frequency amplifiers circuit. Turn the knob fully clockwise for maximum gain and fully counterclockwise for minimum gain. (In the SSB and CW modes, the gain can be controlled thru range of 60 dB or more; in the FM mode, in a range of 40 dB or more.) In the SSB and CW modes, turning the RF GAIN control fully counterclockwise deflects the S meter to full scale and can reduce the internal noise. In the FM mode, the S meter deflection is not affected. Adjust the gain when a high-power signal is received or there is interference from a powerful signal near the receive frequency. Normally the control should remain full clockwise.

15 RIT (Receiver Incremental Tuning) knob

The RIT knob enables you to fine-tune a incoming receive signal without changing the transmit frequency in the SSB or CW mode. The knob operates only when the RIT switch is in the ON position.

16 SQL (Squelch) control

The SQL control is used to eliminate noise during no signal periods. Normally, this control is adjusted clockwise until the noise just disappears and the BUSY indicator goes OFF (Threshold level). For scan operation, this control must be set to the threshold point. This control functions in all modes. When an incoming signal is weak or unstable, readjust the squelch for optimum reception.

17 VOL (Volume) control/POWER switch

Press the POWER switch to turn the power ON; press it again to turn the power OFF. Turn the VOL control clockwise to increase the volume turn it counterclockwise to decrease the volume.

18 NB (Noise Blanker) switch

The noise blanker eliminates impulse noises such as automobile ignition noise. When the NB switch is turned on, noises are reduced or eliminated to provide the optimum reception of weak signals.

Note:

This switch does not operate in the FM mode.

19 COM (Common channel) switch (With the TR-851A/751A)

The COM switch selects the COM channel (common frequency) by the use of a single keystroke operation. The frequency has been factory-set to 433.00 MHz with the TR-851A and 145.00 MHz with the TR-751A, but may be reset to any desired frequency.

TONE switch (With the TR-851E/751E)

This switch activates the repeater control tone (1,750 Hz) circuit.

20 LOW switch

Press this switch to select low power transmit output; press it again to restore high power transmit output.

When this switch is pressed, the transmit output levels change as follows:

HIGH: 25W

LOW: approx. 5W

21 RIT switch

Press this switch to enable RIT; press it again to disable RIT.

Set the RIT switch to ON; the RIT indicator lights. Turn the RIT knob to vary the receive frequency.

If you press the RIT switch in the FM mode, a series of beeps will sound indicating the RIT feature is not enabled.

A. Display panel

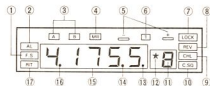

- 1 **F.STEP display:** ON when the F.STEP is ON.
- 2 **AL display:** ON when using AL.
- 3 **VFO display:** ON when VFO A or VFO B is selected.
- 4 **MR display:** ON when MR is selected (Memory channel operation).
- 5 **OFFSET display:** ON when shift is set to "+ +" or "- -" ("D-A" or "D-B" with the TR-851E European version) using the OFFSET key.
- 6 **Tone display:** ON when TONE is selected.
- 7 **LOCK display:** ON when F.LOCK has been selected.
- 8 **REV display:** ON when using the REV function.
- 9 **CHL display:** Flashes during open channel search by CHL key. ON after channel linkage.
- 10 **C.SQ display:** ON when using C.SQ (Code squelch).
- 11 **Channel display:** Normally displays memory channel; displays code channel during digital code display.
- 12 **Stand by indicator:** Specifies which codes will be actively used.
- 13 **50 Hz display:** ON when the second digit is 5; OFF when it is 0.
- 14 **kHz dot:** ON when 50 Hz step is selected; flashes during scan.
- 15 **Frequency display:** Frequency, tone frequency, digital code, and call sign.
- 16 **MHz dot:** Flashes during scan.
- 17 **RIT display:** ON when using RIT.

B. Mode/Numeric keypad

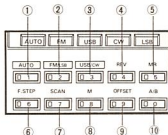

These numeric keypad (1 through 9 and 0) are used to:

- Enter data to memory.
- Input your station call sign and digital code to be used by the DCL system.

① AUTO key

Press this key to enter the AUTO mode; press any other mode key to cancel the mode selection. In AUTO, the mode corresponding to the dial frequency is automatically selected. Normally, use the transceiver in the AUTO mode. (Refer to section 4-2-5.)

② FM/LSB key

Press the FM/LSB key to alternate between FM and LSB.

③ USB/CW key

Press the USB/CW key to alternate between USB and CW.

④ REV (Reverse) key

Use this key to reverse the transmit/receive frequencies during repeater operations. Press the REV key to turn the function on; press it again to turn the function off.

⑤ MR (Memory Recall) key

Activates memory channel operation. Pressing this key causes the MR indicator to light and the current memory channel information to be displayed. There are 10 memory channels, 0 through 9. They can be selected by using the ▲ and ▼ keys described in ①, ③ or the UP and DWN switches on the microphone. When the A/B key is pressed, VFO operation is restored.

⑥ F.STEP (Frequency Step) key

Use the F.STEP key to change the tuning step. Each time it is pressed, the function will be turned ON or OFF. Several step sizes are available depending upon the mode and position of the F.STEP key. (Refer to Section 4-2-4.)

⑦ SCAN key

Press the SCAN key to initiate scanning; press it again to stop scanning.

⑧ M (Memory enter) key

Press the M key to write a frequency into a memory channel or the COM channel (TR-851A/751A only). When the key is pressed, a series of beeps will sound for about 1.5 seconds. To enter a frequency, press the desired numeric key or the COM key during the time that the beeps are sounding.

⑨ OFFSET key

The OFFSET key is used to select the desired transmitter offset for repeater operations. When the key is pressed, the mode cycles from (+) shift, to (-) shift, to simplex, and back to (+) shift. When the offset function is ON, the symbol "+ " or "- " ("D-A" or "D-B" with the TR-851E European version) is displayed.

Note:

The offset function is used only in the FM mode, so if "+ " or "- " ("D-A" or "D-B" with the TR-851E European version) is displayed in the SSB or CW mode, the shift function will not work.

⑩ A/B (VFO A/VFO B) key

- In the VFO mode
Switches operation between VFO A and VFO B.
- In the MR mode
Clears the MR state and restores VFO operation.
- In the COM mode (with the TR-851A/751A)
Clears the COM state and restores VFO operation.

4-1-2. Rear panel

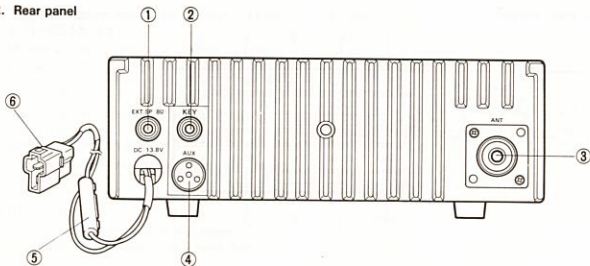

① EXT.SP (External speaker) jack

Use the 8-ohm EXT.SP jack to connect an external speaker.

② KEY jack

Provides connection for the CW key. Use a 3.5 mm dia. plug.

③ ANT (Antenna) jack

Provides connection for a 50-ohm antenna with a male connector.

④ AUX (Auxiliary) jack

Provides connection for linear amplifier control. The AUX jack is wired as shown below. For connection, use the supplied 4-pin plug.

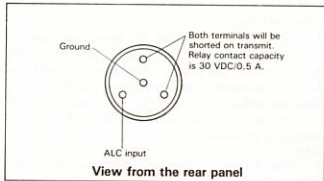

⑤ Fuse holder

Contains the following fuse:

TR-851A/851E: 8A

TR-751A/751E: 7A

⑥ 13.8 VDC power supply jack

Provides connection for the standard 13.8 VDC power supply. Insert the female end of the power cable. Be sure that the red pin has “+” polarity and the black pin has “-” polarity.

4-1-3. Microphone

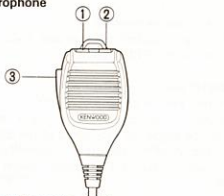

(TR-751A U.S.A. version only)

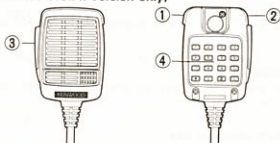

① ② UP/DWN (Up/Down) switches

In the VFO mode, these switches step frequencies up or down one step. When held down, they step the displayed frequencies up or down continuously.

In the MR mode, these switches step memory channels up or down. When held down, they step the memory channels up or down continuously.

The UP switch can be used to select VFO or MR operation, and the DWN switch can be used as the CHL switch. (Please refer to Section 4-9.)

③ PTT (Push to talk) switch

When this switch is held down the transceiver will be placed into the transmit mode. Operations such as scan are cleared when the switch is pressed.

④ 16 Touch-Tone key (TR-751A U.S.A. version only)

Used to activate the touch-tone encoder. (Autopatch operation)

4-2. RECEPTION

4-2-1. Beep tones

Audible confirmation of microprocessor functions is provided in the form of a series of audio beeps. The

volume of the beeps can be adjusted by an internal potentiometer. (See page 36)

Beep tone	Meaning
Short beep	ON. Frequency changed from upper limit to lower limit (or from lower limit to upper limit).
1 long beep	OFF. Channel 1 set during memory channel switching.
1 long beep	Power turned on.
1 long beep	Memory channel written.
2 short beeps	Memory 1 channel busy during alert.
3 short beeps	Error (frequency out of range in OFFSET or REV).
4 short beeps (repeated)	Send frequency ready to be written to memory (When memory channel 9 or 0 keys have been pressed).
5 short beeps	A key operated while LOCK light is ON.
8 short beeps	Standby for memory write (For about 1.5 seconds after M key is pressed).

4-2-2. Initial setting

Connect the power supply and the antenna then set the knobs and switches as follows:

VOL control : Fully counterclockwise

SQL control : Fully counterclockwise

RIT control : Center

RF GAIN control: Fully clockwise

Other switches : All OFF

4-2-3. Reception

In the USB, LSB, and CW modes, the noise level is generally low, so you can usually operate with the SQL control full counterclockwise. This will also help your weak signal reception.

1. Press the POWER switch; the display panel will indicate as shown below and the Meter, the Mode (AUTO and FM with the TR-851A, AUTO and CW with other models) and the BUSY lights will turn on.

(With the TR-851A/851E)



(With the TR-751A/TR-751E)



Note:

If the display is not as shown, reset the microprocessor using the procedure in section 4-4-2.

2. Turn the VOL control clockwise until a QSO or noise is heard; adjust for the desired level. Clockwise rotation of the control will increase the volume and counterclockwise rotation will decrease the volume.
3. To eliminate receiver noise during no-signal periods, slowly adjust the SQL control clockwise until the noise disappears and the BUSY indicator goes OFF (threshold point).
4. Rotate the TUNING knob to the desired frequency. When a signal is received the S meter will deflect and the BUSY indicator will light.

A. SSB zero beating

If the frequency of your station and the distant station are not the same reception of a clear receive signal may be difficult.

(Matching your station's transmit frequency to the distant station's transmit frequency is called "zero beating")

- (a) To zero in, first set the F.STEP key to OFF to roughly tune the other station's frequency in 5 kHz steps, then set the key to ON for fine tuning. When the TUNING knob is slowly turned clockwise in the USB mode, the receive signal becomes lower in pitch. (The reverse effect takes place in the LSB mode.) Rotate the TUNING knob until the clearest most natural sound is heard.
- (b) If the frequency of the other station deviates during the QSO, set the RIT switch to ON and rotate the RIT knob until a natural sound is again received.

B. CW zero beating

Frequency selection in the CW mode is the same as in the SSB mode.

- (a) You can zero beat by rotating the TUNING knob with the RIT switch OFF until the incoming CW signal is 800 Hz (Note).

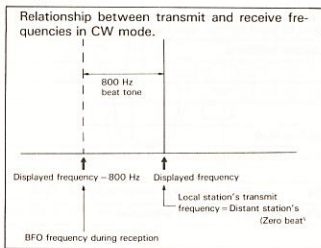

Note:

In CW receive operation, the BFO (Beat Frequency Oscillator) is set 800 Hz below the transmit frequency.

With the transceiver, you can use the sidetone oscillator frequency, about 800 Hz, as a guide for zero beating.

- (b) If the frequency of the distant station deviates from 800 Hz or you wish to have a different tone, set the RIT switch to ON and rotate the TUNING knob until the desired tone frequency is obtained.

4-2-4. Frequency selection

The transceiver contains two digital VFOs, VFO A and VFO B, having a minimum tuning rate of 50 Hz steps and 10 memory channels (1 thru 9, and 0) for easy selection of often used frequencies. The TR-851A/751A also contains a COM channel. Normally the TUNING knob would be used for frequency selection, but thru the use of the MR, A/B, Up/Down (▼ MHz/M.CH ▲) F.STEP and COM (TR-851A/751A only) keys in combination with the TUNING knob. Rapid frequency changes are possible.

A. 2 VFO (A/B)

You can change frequencies using the TUNING knob or the microphone UP/DWN switches. When VFO A or VFO B is selected using the A/B switch, "A" or "B" appears on the display panel.

VFO A and VFO B independently store data such as frequency, mode, RIT switch ON/OFF status, F.STEP switch status, TONE status, off-set frequency, and tone frequency (TR-851A/751A only).

Example:

Operating VFO A in FM and VFO B in SSB

VFO A: 475 FM, F.STEP OFF

VFO B: 5900.0 USB, F.STEP ON

B. MR (Memory Recall) channels

Press the MR key; "MR" will appear on the display panel, indicating that the transceiver is in the memory channel call state. Press the A/B key to return the unit to VFO A or VFO B.

Memory recall can be selected using the Up/Down (▼ MHz/M.CH ▲) key or the microphone UP/DWN switch while "MR" is displayed on the panel (Memory entry instructions, see page 19). When the TUNING knob is rotated while "MR" and the frequency of the selected memory channel are displayed on the panel, memory channel operation will be cancelled and the transceiver will return to VFO operation. Frequencies can be changed using the VFO by noting the frequency selected when "MR" was on the display panel. (See "Memory shift".)

C. COM (Common) channel (With the TR-851A/751A)

Press the COM key; the COM indicator lights and the COM channel mode is selected. Press the key again to return to the previous mode. Pressing the MR key while "COM" is displayed selects the memory channel mode; pressing the A/B key selects VFO A or VFO B.

Note:

When "COM" is displayed, frequencies cannot be changed using the TUNING knob, the ▼ MHz/M.CH ▲ key, or the microphone UP/DWN switches. The COM channel is factory-set to 433.000 MHz with the TR-851A and 145.000 MHz with the TR-751A, but may be reset to any desired frequency. (See page 19)

D. Frequency step

The step size in which frequencies are changed by the TUNING knob or the microphone's UP or DWN push buttons can be changed by the SCAN key, the mode key and/or the F.STEP key.

MODEL F.STEP SCAN	TR-851A		TR-751A		TR-851E TR-751E	
	OFF	ON	OFF	ON	OFF	ON
FM	OFF kHz	5 kHz	5 kHz	10 kHz	12.5 kHz	5 kHz
USB	OFF	5 kHz	5 kHz	50 Hz	5 kHz	50 Hz
LSB	ON	1 kHz	1 kHz	1 kHz	1 kHz	1 kHz
CW						

E. Memory shift

This feature shifts the memory channel data to the VFO. This will allow you to alter the frequency or mode without changing the contents of the memory channel. "MR" disappears from the display panel and "A" or "B" (The VFO used before the memory channel operation was started) appears. Press the MR key to return to the memory channel.

4-2-5. Mode selection

A. Manual mode selection

Most operations can be performed in the AUTO mode. In the following operations, you must select the appropriate mode using the FM/LSB and USB/CW keys (when any of these keys is pressed, the AUTO mode is released):

- TX QSX (Change frequency while transmitting) for satellite communication or other applications.
- Memory channel mode scan.

Present mode	New mode	Key	Press
AUTO	FM	FM/LSB	1
	USB	USB/CW	1
	LSB	FM/LSB	2
	CW	USB/CW	2
FM	AUTO	AUTO	1
	USB	USB/CW	1
	LSB	FM/LSB	1
	CW	USB/CW	2
USB	AUTO	AUTO	1
	FM	FM/LSB	1
	LSB	FM/LSB	2
LSB	CW	USB/CW	1
	AUTO	AUTO	1
	FM	FM/LSB	1
CW	USB	USB/CW	1
	CW	USB/CW	2
	AUTO	AUTO	1
	LSB	FM/LSB	2

B. AUTO mode

The AUTO mode function automatically sets the mode to correspond to the selected frequency as shown below, which is especially convenient for mobile operations.

Note:

During transmission in the AUTO mode, TX QSX is disabled. To switch frequencies while transmitting for satellite communication or other similar applications, select USB, LSB or CW.

(With the TR-851A)

430.0	435.0	438.0	440.0
FM	LSB	FM	

(With the TR-851E)

430.0	432.15	432.5	435.0	438.0	440.0
CW	USB	FM	LSB	FM	

(With the TR-751A)

144.0	144.1	144.5	145.8	146.0	148.0
CW	USB	FM	USB	FM	

(With the TR-751E)

144.00	144.15	144.50	145.85	146.00
CW	USB	FM	USB	

C. Audible mode announcement

When a mode key is pressed, the first character of the new mode is sounded in Morse code thru the speaker.

4-2-6. AGC (Automatic Gain Control)

In the SSB and CW modes, the AGC circuit minimizes the variation in the sound output caused by variations in the incoming receive signal strength. The AGC time constant is automatically set by mode as follows:

USB and LSB.....SLOW
CWFAST

4-3. TRANSMISSION

4-3-1. Precaution

Before transmitting check the frequency for activity so that you do not interrupt another QSO.

4-3-2. FM, SSB (USB, LSB) mode

1. Connect the microphone and press the PTT switch. The transceiver will enter the transmit mode and the ON AIR indicator will light.
2. Speak into the microphone, holding the microphone about 5 cm away from your mouth. Close talking or talking too loudly may reduce transmission clarity or spread the side bands too much.
3. Release the PTT switch to return to receive ; the ON AIR indicator will OFF.

4-3-3. CW mode

A. Semi break-in

Switching between transmit and receive in the CW mode is performed using semi-break-in. In semi-break-in, when the key is closed, transmit is automatically selected when the key is opened, receive is selected, after a short delay. You can thus switch between transmit and receive automatically by using the key alone. The time (or the delay) between opening the key and returning to the receive state can be internally adjusted. (See page 35)

B. Sidetone oscillator

The transceiver contains a sidetone oscillator circuit to permit you to monitor your own signal. If the key is closed in a mode other than CW, transmit will not be selected but a sidetone will come out of the speaker, to allow Morse code training. The volume of the sidetone can be adjusted internally. (See page 35.)

4-4. MEMORY

4-4-1. Microprocessor memory back-up

A lithium battery is contained in the transceiver to retain memory. Turning off the POWER switch, disconnecting the power cable, or a power failure will not erase the memory. The battery should last for approximately five years. When the battery discharges, an erroneous display may appear in the display.

(For the lithium battery replacement, refer to section 5-5.)

4-4-2. Initial state and reset of the microprocessor.

A. Initial state of the microprocessor from the factory.

MODEL	TR-851A		TR-851E		TR-751A		TR-751E	
	Frequency (MHz)	Mode	Frequency (MHz)	Mode	Frequency (MHz)	Mode	Frequency (MHz)	Mode
VFO A	430.000	AUTO, FM	430.000	AUTO, CW	144.000	AUTO, CW	144.000	AUTO, CW
VFO B	430.000	AUTO, FM	430.000	AUTO, CW	144.000	AUTO, CW	144.000	AUTO, CW
COM	433.000	AUTO, FM	—	—	145.000	AUTO, FM	—	—
M. CH1	430.000	AUTO, FM	430.000	AUTO, CW	144.000	AUTO, CW	144.000	AUTO, CW
M. CH7	430.000	FM	430.000	FM	144.000	FM	144.000	FM
M. CH2 ~ 6, 8, 9, 0	—	FM	—	FM	—	FM	—	FM

B. Microprocessor initialization

To erase all data from the memory or reset the microprocessor, you may initialize the microprocessor from the front panel as follows:

1. Turn the POWER switch off.
2. Turn the POWER switch on while pressing the M key.
3. Release the M key.

4-4-3. Memory channel

The 10 memory channels (1 through 9, and 0) are available for data entry. Channels 9 and 0 can store transmit and receive frequencies separately for use with "odd-split" repeaters. Channels 1, 7, 8, and 0 have the following functions:

(a) **Channel 1**

Channel 1 is the priority alert channel.

(b) **Channel 7**

Channel 7 contains the beginning frequency used during a search for an open channel when the DCL system is operating.

(c) **Channel 8**

The frequency entered in channel 8 is excluded during the open channel scanning when the DCL system is operating.

(d) **Channel 0**

This channel is used to select the program scan frequency range.

Note:

These channel can be used as normal memory channels when they are not used to perform these other functions.

4-4-4. Split memory

Channels 9 and 0 can store transmit and receive frequencies separately. Use these channels when a repeater system having an offset frequency other than the offset shown in the table of Section 4-6-1. OFFSET feature is used. They are useful for an operations in which the transmit and receive frequencies need to be different such as when the operating split frequencies during DX communications.

Storing the same transmit and receive frequencies in these channels makes them operate as ordinary memory channels.

Note:

Channels 9 and 0 can store frequencies in units of 100 Hz.

4-4-5. Data entry

In addition to frequency, the memory channels can store such data as mode, F.STEP status, offsets, TONE status (except TR-851E/751E European version), and TONE frequency (TR-851A/751A only) as shown below.

MODEL CHANNEL	TR-851A/751A	TR-851E/751E	
		European version	U.K. version
VFO A and VFO B	Frequency data Mode data F. STEP ON/OFF RIT ON/OFF OFFSET + - TONE ON, OFF Tone frequency data	Frequency data Mode data F. STEP ON/OFF RIT ON/OFF OFFSET + - (TR-751E) OFFSET D-A D-B (TR-851E)	Frequency data Mode data F. STEP ON/OFF RIT ON/OFF OFFSET + - TONE ON, OFF
M. CH 1 - 8	Frequency data Mode data F. STEP ON/OFF OFFSET + - TONE ON, OFF Tone frequency data	Frequency data Mode data F. STEP ON/OFF OFFSET + - (TR-751E) OFFSET D-A D-B (TR-851E)	Frequency data Mode data F. STEP ON/OFF OFFSET + - TONE ON, OFF
M. CH 9 and 0	Frequency data Transmit frequency data Mode data F. STEP ON/OFF TONE ON, OFF Tone frequency data	Frequency data Transmit frequency data Mode data F. STEP ON/OFF	Frequency data Transmit frequency data Mode data F. STEP ON/OFF TONE ON, OFF
COM (Common) channel	Frequency data Mode data OFFSET + - TONE ON, OFF Tone frequency data	_____	_____

A. ENTRY of the current display data (i.e., frequency and mode)

	Operation	Key	Beep	Remarks
1	Press M key	M	8 Beeps	Press M key while the beeps are sounding (about 1.5 seconds).
2	Press the desired channel key.	1 to 8	Long beep	This beep indicates the completion of data entry (completed).
		9 or 0	One long, 4 short beeps	Perform this operation for channel 9 or 0.
3	Press 9 or 0 again for channel 9 or 0.	9 or 0	Long beep	The same frequency is stored for both transmit and receive*. (Completed)

B. Displayed data (i.e., frequency and mode) is different from the data to be stored.

Note:

- Following step 2, set the F. STEP ON/OFF, OFF-SET and TONE (except TR-851E European version) as required. (TR-851A/851E only)
- Following step 2, set the F.STEP ON/OFF as required. (TR-751A/751E only)

	Operation
1	Select the frequency to be stored.
2	Select the mode.
3	Select the offset information.
4	Select the tone information. (Except TR-851E/751E European version)
5	Operations 1 to 3 of A above.

C. Entering different transmit and receive frequencies into split memory (Channel 9 or 0)

	Operation	Key	Beep	Remarks
1	Select the receive frequency. f_r (100)	TUNING knob ▼, ▲, F.STEP	—	—
2	Set 2 to 4 of B above.	—	—	Refer to B above.
3	Press the M key.	M	8 beeps	
4	Press the desired channel.	9 or 0	1 long, 4 short beeps	Beep to request transmit frequency storage keeps sounding until the transmit frequency has been entered.
5	Select the transmit frequency	TUNING knob ▼, ▲, F.STEP	4 beeps continuously repeated	See Note.
6	Press the same key as in 4 above.	9 or 0	Long beep	Storage completed.

Note:

When the repeated 4 beeps sounds during a split memory storing operation (Memory channel 9 or 0), all keys except the TUNING knob, ▼, ▲ F.STEP, and

M keys are invalid. This beep keeps sounding after the power is turned on or off. To silence it, press the 9 or 0 key.

D. Storing data into the COM channel (With the TR-851A/751A)

	Operation	Key	Beep	Remarks
1	Select frequency.	TUNING knob ▼, ▲, F.STEP	—	Select the frequency to be stored in the COM channel.
2	Select any other desired information.	—	—	Perform operations 1 to 4 in B above.
3	Press the M key.	M	8 beeps will sound (8 times)	Press are the COM key while the beeps sounding (for about 1.5 seconds).
4	Press the COM key.	COM	Long beep	This beep indicates that data has been stored in the COM channel. (Completed).

4-5. SCAN

The following scan options are available:

- Program scan ("A" or "B" is displayed during VFO operation.)
- Memory scan (AUTO mode is ON during memory channel operation.)
- Memory channel mode scan (AUTO mode is OFF during memory channel operation.)

4-5-1. Scan operation

(a) Scan stop conditions

The transceiver will stop on a busy channel during normal scan operations. When an incoming signal is detected during frequency scanning the BUSY indicator will light. In order for this function to operate the SQL control must be adjusted to the threshold point.

You may change the transceiver to stop on an open channel rather than a busy channel.

Please see page 35 for the procedure.

(b) Scan indication

During frequency scanning, the MHz or kHz (for 50 Hz step) dot will blink.

(c) Scan direction

Scanning begins in the up direction and reverses if the TUNING knob is turned counterclockwise or the microphone's DWN switch is pressed.

(d) Frequency step in scan mode

In the program scan mode, frequencies are scanned using the normal steps. In the SSB or CW mode and when the F.STEP key ON frequencies will be scanned in 1 kHz steps. (Refer to section 4-2-4.)

4-5-2. Programmable band-scan

During VFO operation, the scan frequency range is determined by the frequency displayed and the frequency stored in channel 0 as follows:

(a) In-range scan

If SCAN is initiated while the displayed frequency is between the limits specified in memory channel 0, scan will proceed between these two frequencies.

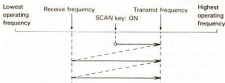

(b) Out-of-range scan

If SCAN is initiated while the displayed frequency is outside the range specified in memory channel 0, scan will proceed outside the range specified by these two frequencies.

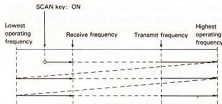

(c) All band scan

When the same transmit/receive frequency is stored in memory channel 0, the scan will proceed over the entire band.

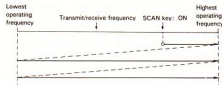

4-5-3. Memory scan

When the AUTO mode is ON, during memory channel operation, pressing the SCAN key will cause the radio to scan the memory channels repeatedly, skipping the channels that have no data stored.

4-5-4. Memory channel mode scan

Select the desired mode and then initiate scan. Only those channels with the specified mode will be scanned.

4-5-5. Scan release

Press one of the following keys during scanning to clear the scan mode:

- SCAN key
- PTT switch
- Others (except ∇ MHz/M.CH \blacktriangle , NB, LOW, FUNC, and VOICE keys)

4-5-6. Scan hold

Scanning resumes about 6 seconds after stopping. This is called TO (Time Operated) scan. It can be changed to CO (Carrier Operated) scan, in which the scan holds during signal reception and resumes about 1.5 seconds after the input signal disappears. Scanning will resume when the TUNING knob is turned or the microphone UP/DWN switch is pressed during scan hold.

4-5-7. Priority alert

Memory channel 1 is monitored at about 6 seconds intervals to check for activity. The displayed frequency will drop out during the scan interval. If the channel is busy, the transceiver alerts the operator with two beeps.

Operation

1. Press the FUNC key then the AL key; "AL" will appear on the display panel.
2. Press the keys again and "AL" will disappear, disabling the alert function.

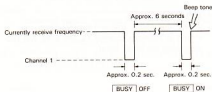

Note:

During the period channel 1 is being scanned, only the beep will sound.

4-6. REPEATER

4-6-1. OFFSET feature

This feature causes the transmitter frequency to shift above or below the receiver frequency. The amount of the offset (shift) is shown in the table below.

RELATIONSHIP BETWEEN DISPLAY AND OFFSET FREQUENCY

MODEL DISPLAY	TR-851A	TR-851E		TR-751A TR-751E
		European version	U.K. version	
+	+5 MHz	_____	+1.6 MHz	+600 kHz
-	-5 MHz	_____	-1.6 MHz	-600 kHz
D-A	_____	-7.6 MHz	_____	_____
D-B	_____	-1.6 MHz	_____	_____

Operation

You can select the desired transmitter offset by repeatedly pressing the OFFSET key. The display will indicate which offset has been selected by turning on a small bar under the selected offset. In simplex mode no bar will show under the "+" or "-" ("D-A" or "D-B" with the TR-851E European version).

4-6-2. REV (Reverse) feature

The REV switch reverses the transmit and receive frequencies when using an OFFSET or split frequency memory (channel 9 or 0).

This function is used to check the repeater's input frequency or operate on reverse repeater (Pairs the input/output frequencies are opposite to those of a normal repeater).

Operation

To use the REVERSE function press the REV key. The REV indicator in the display will illuminate and the displayed frequency will change to the old transmit frequency. The radio will now transmit on the old receive frequency when the PTT switch is depressed.

Note (TR-751A/751E only):

To use the F.STEP function press the F.STEP key before pressing the REV key.

If the F.STEP key is activated while in the REV mode the radio will revert back to the original receive frequency. You can cancel this by turning the TUNING knob or pressing the PTT switch.

4-6-3. Tone frequency

A. With the TR-851A/751A

The TONE switch turns on and off the subaudible tone encoder for repeater control. Use this function with the optional programmable tone unit TU-7. Any of 38 tone frequencies may be selected by rotating the TUNING knob on the front panel. The tone ON/OFF condition and the selected tone frequency can be stored separately in VFO A or VFO B, the COM channel or memory channels 0 through 9.

Available CTCSS tone frequencies

Hz	Hz	Hz
67.0	114.8	192.8
71.9	118.8	203.5
74.4	123.0	210.7
77.0	127.3	218.1
79.7	131.8	225.7
82.5	136.5	233.6
85.4	141.3	241.8
88.5	146.2	250.3
91.5	151.4	
94.8	156.7	
97.4	162.2	
100.0	167.9	
103.5	173.8	
107.2	179.9	
110.9	186.2	

Operation

1. Turning the tone ON/OFF

Press the FUNC switch then the TONE switch; the T indicator lights indicating that the tone is ON.

Press the FUNC and TONE switches again, and the T indicator goes OFF, indicating that the tone is OFF.

2. Selecting a tone frequency

Press the FUNC switch then hold the TONE key down for more than 0.5 seconds; the tone frequency will be displayed. Select the desired frequency by rotating the TUNING knob (or with the microphone UP/DWN switch). When FUNC key is pressed, the display returns to the original operating frequency.

(a) Selecting the audible tone frequency (With the optional TU-7 installed)

	Key operation	Display	No. of beeps
Switching to tone display	1. Press FUNC key.	FUNC light ON	1 beep
	2. Press TONE key for more than 0.5 seconds.	About 0.5 seconds after T light ON, tone frequency will be displayed.	1 beep or 1 long 1 beep
	3. Release TONE key.	FUNC light OFF.	—
Selecting tone frequency	4. Turn TUNING knob right or left. (Or operate microphone UP/DWN switch)	38 frequencies are scrolled.	—
Return to frequency display	5. Press FUNC key.	The original frequency is displayed. T light ON.	1 beep

Note:

When tone display is returns to the normal display, the T indicator always will be ON and the tone feature enabled.

(b) TONE ON/OFF operation

	Key operation	Display	No. of beeps
TONE ON	1. Press FUNC key.	FUNC light ON	1 beep
	2. Press TONE key.	T light ON FUNC light OFF	1 beep
TONE OFF	1. Press FUNC key.	FUNC light ON	1 beep
	2. Press TONE key.	T light OFF FUNC light OFF	1 beep

B. With the TR-851E/751E European version

The TONE switch turns the 1750 Hz single tone for repeater control ON or OFF.

Operation

When you hold the TONE switch down, the unit is in the send mode and the tone is modulated; the ON AIR and T indicators are ON.

C. With the TR-851E/751E U.K. version

The TONE switch turns the tone burst for repeater control ON or OFF.

Operation

Press the TONE switch; the T indicator lights. The 1750 Hz tone signal is sent for approximately 1 second.

4-7. DCL (Digital Channel Link) SYSTEM

4-7-1. DCL system description

(The optional MU-1 Modem unit is required for DCL system operation).

The DCL system provides a convenient automatic method of OSY'ing to an open simplex channel. The system is microprocessor controlled for speed and reliability, and offers several original features not previously available in amateur radio.

DCL System features

- The DCL system searches, on command, for an open channel, remembers the frequency, returns to the original operating frequency and transmits control information to the receiving station that switches both radios to the open channel. Microprocessor control assures fast and reliable operation of the DCL system.
- The recall and reverse functions are provided to ensure communications are not lost if the channel linkage operation fails for any reason.
- Digital code squelch operations are provided that utilize a five digit access code, and may be used in conjunction with the DCL feature. Five DCS memory positions are provided. The transceiver can use any or all of the code memories if desired.
- Squelch will open only when the transmitting station, and the receiving stations codes match.
- Automatic transmission and display of call sign data. (Display of call sign data requires the use of the CD-10 Call Sign Display). Up to 6 characters can be input for automatic transmission when the DCL system is turned on.

Notes:

- The DCL system operates only when the optional MU-1 Modem unit is attached. When the system is operated without the MU-1, data (Control signals) will not be exchanged with the distant station although the keys on the system operate.
- The DCL system is intended for efficient communication in the FM mode. Therefore, the system does not operate in the USB, LSB, and CW modes. When the FM mode is switched to any other mode during a DCL system operation, all DCL-related functions are deactivated.

4-7-2. Control signal

The DCL system operates by transmitting a control signal that contains call sign data, digital access code information, and open channel control information.

This signal is transmitted under the following conditions:

- The PTT switch is pressed and released when the DCL light is ON.
- The OPEN channel data is sent to the distant station during a channel linkage operations.

-Code squelch control signal (Without open channel data)
-Channel linkage control signal (With open channel data)

1. When the DCL system is operating:

[When the DCL switch is ON (DCL light ON), the control signal is sent for about 0.2 seconds at the beginning and end of each transmission.]

(a) Simplex mode

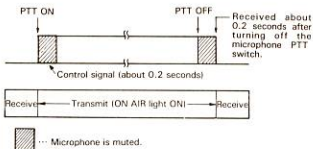

Don't start talking after a short delay to allow the DCL/DCS control signal to be transmitted without interference.

(b) OFFSET mode

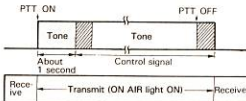

When the OFFSET switch is ON, the control signal is transmitted about 1 second after the PTT switch is activated. This delay prevents the control signal from being broken by the slow response of some repeaters.

Notes:

- The tone is not modulated. (With the TR-851E/751E European version)
- The 1750 Hz tone is modulated for the first second. (With the TR-851E/751E U.K. version).

2. When the channel linkage system is operating:
[When the CHL switch is ON (CHL indicator will be ON), the control signal will be automatically transmitted for about 0.2 seconds.]

(a) Simplex mode

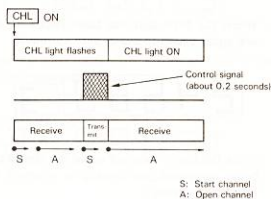

(b) OFFSET mode

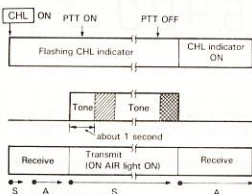

4-7-3. DCL system keyboard

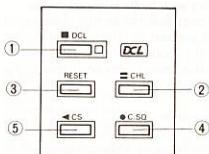

① DCL (Digital Channel Linkage) key

Press the DCL key to turn on the DCL system, press it again to turn the system off. When the DCL system is ON, the DCL light is ON. This key is valid only in the FM mode. When the system is ON, it waits for channel linkage, or DCS data during receive; during transmission the system sends the control signals at the beginning and end of each transmission.

② CHL (Channel Linkage) key

If you press the CHL key while the DCL light is ON, the DCL system begins a channel linkage operation to shift the operating frequency of both your radio and any distant station equipped with the DCL system to the 1st available open simplex frequency. During the SCAN process, the CHL indicator will flash. When the linkage has been completed, the indicator will steadily be ON. If you press the CHL key while the CHL light is ON, the system performs a recall operation. (See page 29.)

③ RESET key

If the RESET key is pressed during channel linkage operation or after its completion, the channel linkage operation is cancelled. (The CHL indicator goes OFF.) When the RESET key is pressed after the operation is cleared, the system performs a reverse operation. (See page 29.) You can also use this key to alternate between the open channel and the original operating frequency or to abort the entry of your station's call sign. Pressing the RESET key when the digital code is displayed alternates between the digital code display and the call sign display.

④ C.SQ (Code Squelch) key

Press the C.SQ key to turn on the code squelch function; press it again to turn the function off. When the function is ON, the C.SQ light is ON. During digital code display, the key functions as the standby indicator.

⑤ CS (Code Set) key

Use the CS key to enter the digital access code and call sign into memory. Pressing this key alternates between the digital access code display and transmit/receive frequency display.

Press the key to turn on the digital code, display and enable the entry of digital access code information by using the numeric keypad.

Press the key again to turn the digital code display off and turn the frequency display on.

4-7-4. Digital access code entry

Each of the DCL system functions operate between transceivers that have the proper digital access code. The digital access code is a 5 digit number from 00000 to 99999, which yields approximately 100,000 different combinations.

Five access code memories are provided. You can select which of the 5 codes you wish to use or listen for. Only one of the codes will be used for transmission. The microprocessor controls which of the codes is used for transmission when you are listening for more than one code. For example when an incoming code is received the microprocessor determines if it is one of the codes that it was waiting for.

If the code is one of the "active" codes the microprocessor determines if it matches the current "transmit code". If the codes match no further action is required, but if the codes do not match the microprocessor switches the transmit code to the same code as the incoming code to allow normal communications.

A. Storing the digital access code

Example: Store the following digital codes:

- 1, 2, 3, 4, 5 in code channel 1
- 2, 4, 6, 8, 0 in code channel 3

- Press the CS key.
The digital code channel 1 will be displayed. (An example is factory-preset)



- Key in the digital code 1, 2, 3, 4, 5, using the numeric keypad.

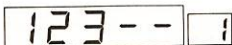

- When the fifth digit has been keyed in, a long beep will sound to signal that the code has been entered into memory.

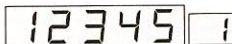

- Rotate the TUNING knob to code channel 3.



- Key in the digital code as 2, 4, 6, 8, 0.



- When the fifth digit has been keyed in, a beep will again sound to signal data storage.



- If the CS key is pressed while the digital code is being displayed, the display is returned to the frequency display.



B. Transmit code

The digital code that appears when the CS key is pressed is the transmit code. The transmit code is also an active standby code if no standby code is active any signal containing the proper standby code that is received and causes a channel linkage or code squelch operation to be performed will also cause microprocessor to select the same access code for transmit, to allow 2-way communications.

C. Specifying waiting with multiple digital codes

The transmit digital code is the code that is displayed when the CS key is pressed to return to the normal frequency display. This code operates as an active standby code in receive, along with any other codes with the standby indicator ON.

To activate a standby code:

For example, use the 1, 2, 3, 4, 5, code stored in code channel 1 as the transmit code and the 2, 4, 6, 8, 0 code stored in code channel 3 as an active standby code.

- Press the CS key; the digital code display will appear.

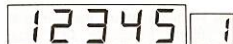

- Rotate the TUNING knob to display code channel 3.



- Press the C.SQ key. The standby indicator (★) will be displayed.



To cancel standby on this code, press the C.SQ key again. The standby indicator will go OFF and the code will become inactive.

- Rotate the TUNING knob to display code channel 1.

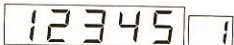

- When the CS key is pressed, the display will return to the normal frequency display. Code channel 1 will now be the transmit code, and also function as an active standby code.



Note: _____
Call sign and digital code data are retained after the power is turned off.

4-7-5. Code squelch

In this squelch system, a digital code is preset by the local station and the distant station (or among a group); when the digital code of the transmitting station matches the receiving stations digital code squelch will open and normal communications can be carried out. This system allows the receiving station to wait (or standby) for more than one access code at the same time.

Code squelch has the following features:

- Errors are minimized due to microprocessor control.

- Multiple digital code monitoring.
- Each digital code consists of a 5-digit number, providing approximately 100,000 possibilities.
- Simultaneous channel linkage and code squelch operation is possible.

When the C.SQ key is pressed, incoming signals will be muted until the proper access code is received.

Code squelch is cleared when any of the following conditions are met allowing normal voice communications:

- The digital access code of the control signal received from the distant station matches the local station's standby code.
- The C.SQ key is pressed.
- The DCL key is pressed and the DCL light goes OFF.
- The PTT switch is pressed.

A. Standby

- Select the desired standby digital code.
- Press the C.SQ key while in the FM mode; C.SQ will be displayed. The speaker output will be muted regardless of the SQL control setting.
- If a control signal that has the correct standby code is received, squelch will open and a normal voice signals will be heard from the speaker. Simultaneously 3 beeps will sound, the C.SQ display goes OFF and code squelch is cleared.
- To cancel code squelch, press the C.SQ key, the DCL key or the PTT switch.

B. To open the squelch of a distant station

- Select the desired transmit digital code.
- Press the DCL key; the DCL light will go ON.
- Press the PTT switch. The control signal will be sent at the beginning and end of the transmission to cause the distant station to open its squelch.

4-7-6. Code scan

You can initiate scan operations that will only stop scanning when the proper access code is received with the following procedure.

- Press the C.SQ key to initiate code squelch.
- Select the desired standby digital code.
- Press the SCAN key; scanning will begin.
- When a control signal with the proper digital code is received during scanning, the C.SQ light will go OFF, normal voice signals will be heard from the speaker, and the scan will be cleared.

4-7-7. Channel linkage

The channel linkage feature allows you to shift from the present frequency to the first available open channel by a single touch of the button when there is interference between communication channels.

When the CHL key is pressed, the following operations take place in sequence (This is called the Channel Linkage operation.):

Channel linkage operation

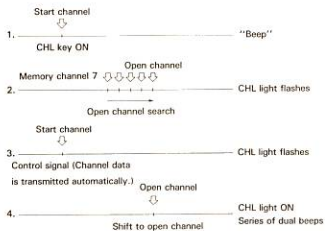

1. The frequency displayed when the CHL key is pressed is stored in memory as the start channel.
2. A search for an open channel begins.
3. The start channel is recalled. The data (Control signal) including the open channel frequency is transmitted (Requires approximately 0.2 seconds).
4. Control is passed to the open channel.

A channel linkage operation can begin from any frequency within the band.

Open channel search range:

An open channel search operation will search up to 11 channels from the frequency stored in memory channel 7. (A total of 12 channels). Store the start frequency in channel 7.

Open channel search proceeds in steps according to the table shown below.

TR-851A/851E	TR-751A	TR-751E
25 kHz	15 kHz*	25 kHz

Notes:

1. Scan will begin from the frequency stored in Memory Channel 7 in the FM mode.
2. The frequency stored in Memory Channel 8 will be skipped even if it is within the open channel scan range.
3. * Step size can be altered to 20 kHz if desired. (See page 36.) (TR-751A only)

Open channel criteria

If squelch is closed (BUSY LED is OFF) for more than 1.5 seconds, the channel is considered to be the open channel.

A. Initiating channel linkage

(A) Simplex mode

1. Press the DCL key; the DCL light will go ON.
2. When no signal is received, adjust the SQL control until the BUSY indicator just goes OFF.
3. Press the CHL key. When the CHL key is pressed, the microprocessor performs the operations 1 through 4 in Fig. shown above, passing control to the open channel automatically. During this operation, the CHL indicator flashes and speaker output is muted.
4. 3 beeps will sound and the CHL indicator is ON, indicating that the channel linkage has been completed.
5. Communicate with the distant station on the new channel.

(B) Shifting to a simplex channel from a repeater

When repeater operation has been selected "+" or "-" ("D-A" or "D-B" with the TR-851E European version) will be displayed. Follow the steps below:

1. Press the DCL key; the DCL light goes ON.
2. When no signal is received, adjust the SQL control until the BUSY indicator just goes OFF.
3. Press the CHL key.
The microprocessor performs operations 1 and 2 in Fig. shown above to automatically search for an open channel and then returns to the start channel (the repeater channel). A series of 3 beeps will sound.
4. When the repeater becomes open, press the PTT switch. About 1 second later, the control signal will be transmitted to open code squelch on the distant station.
5. Release the PTT switch. The control signal containing the open channel information will then be transmitted.
6. About 0.2 seconds after the control signal is transmitted, the open channel will be selected automatically. A series of 3 beeps will sound and the CHL indicator will be displayed. Simultaneously, the offset indicator goes OFF.
7. The radio is now on the open channel, in simplex mode and ready for communication with the distant station.

(a) No open channel is found (Reset feature)

Occasionally many stations may be on the air, making it hard to find an open channel, causing the CHL indicator to continually flash and the frequency display to continue to scan continuously. In such cases, press the RESET key or the PTT switch to return to the original frequency.

(b) The start channel remains busy

When the original frequency is busy, the control signal cannot be sent to the distant station (The CHL display will keep flashing. 3 beeps will continue to sound, and normal voice signals will be heard from the speaker).

When the start channel becomes open momentarily, the control signal will be automatically transmitted.

If you press the PTT switch when the start channel is busy, the control signal is transmitted, allowing you to shift to the open channel. (To cancel the PTT switch operation, press the RESET key.)

(c) The distant station does not shift to the open channel (Recall feature)

The distant station may not shift to the open channel during channel linkage operations because it has failed to receive the control signal due to interference or weak signals.

Press the CHL key again. Operations 3 and 4 in figure shown on page 28 will be performed again automatically, allowing you to complete the channel linkage operation. Press the CHL key while CHL display is ON. When CHL goes OFF, initiate a new channel linkage operation.

(d) Manually informing the distant station of the open channel (Reverse feature)

When the distant station does not shift to the open channel after several recall attempts, or the distant station does not have the DCL system, you can manually return to the start channel to vocally inform the other station of the open channel frequency. Follow the steps below:

1. Press the RESET key; the CHL display goes OFF.
2. Press the RESET key again; the frequency of the start channel will be recalled.
3. Press the PTT switch and vocally inform the distant station of the open channel frequency.
4. Press the RESET key once more; the open channel frequency will be selected.
5. You can alternately shift between the start channel and the open channel each time the RESET key is pressed.

(e) Reinitiating the channel linkage operation

If the selected open channel has interference, you can reinitiate the channel linkage from the start channel.

Follow the steps below:

1. Press the RESET key; the CHL display goes OFF.
2. Ask the distant station to press RESET.
3. Press the CHL key.

When the RESET key is pressed at each station, you can reinitiate the channel linkage.

B. Channel linkage operations initiated by the distant station

The distant station operates the channel linkage to search for an open channel while you wait.

1. Make sure that the distant stations transmit digital code matches your receive code.
2. Press the DCL key; the DCL light will go ON.
3. Ask the distant station to press his CHL key. The control signal will come from the distant station.
4. Control shifts to the open channel found by the distant station; a series of 2 beeps will sound and the CHL indicator will be displayed.
5. Both your station and the distant station have now shifted to the open channel.

C. DCL system notes

(a) When CHL or LOCK is displayed, you cannot shift to a open channel.

If CHL is displayed with channel linkage completed or if LOCK is displayed indicating that the F.LOCK key has been pressed, you will not be able to shift to an open channel if you receive the control signal from the distant station.

You can prevent an abrupt shift to an open channel which may be caused by the control signal of any distant station during code squelch operations, or other DCL signals from other users, by ensuring the DCL indicator is ON.

(b) During AUTO mode operation, take the following precautions:

If the open channel found during channel linkage operations from the distant station is outside the FM range in the AUTO mode, clear the AUTO mode (Turn off the AUTO display) before starting the open channel shift operations or channel linkage will not occur.

(c) Channel linkage on the COM or memory channel recalls the VFO mode

When a channel linkage operation is initiated in the COM (with the TR-851A/751A) or memory channel mode, the transceiver will recall the previous VFO frequency (A or B) before the actually performing the shift to the open channel.

4-7-8. Call sign entry

Up to 6 characters can be entered for automatic transmitter identification. The call sign is entered using ASCII codes from the numeric keypad on the front of the radio. This data is then transmitted whenever the DCL switch is ON. A unique feature of this system is that when the CD-10 Call sign display is connected you will be able to decode this ASCII call sign information and display the call sign of the incoming signal alphanumerically.

Decimal ASCII code

0 : 48	A : 65	K : 75	U : 85
1 : 49	B : 66	L : 76	V : 86
2 : 50	C : 67	M : 77	W : 87
3 : 51	D : 68	N : 78	X : 88
4 : 52	E : 69	O : 79	Y : 89
5 : 53	F : 70	P : 80	Z : 90
6 : 54	G : 71	Q : 81	/ : 47
7 : 55	H : 72	R : 82	SPACE: 32
8 : 56	I : 73	S : 83	
9 : 57	J : 74	T : 84	

- Convert your call sign into decimal notation. Refer to table shown above to convert your call sign into its decimal ASCII equivalent.

Example:

Call sign : W D 6 D J Y
 Decimal ASCII : 87 68 54 68 74 89

Your call sign					
Decimal ASCII notation					

Note:

Enter leading or trailing spaces (32) for call signs of less than 6 characters.

- In the FM mode, press the CS key. A digital access code will be displayed.



- Press the RESET key. The first three characters (Six ASCII digits) of the call sign are displayed.

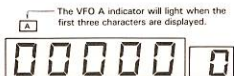

- Key in the first three characters (Six ASCII digits) of your call sign.

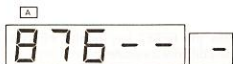

For example, call sign WD6DJY is keyed in as 8, 7, 6, 8, 5, 4.

- When the first three characters have been keyed in, a long beep will sound and the display will be switched to the display for the final three characters (Six digits).

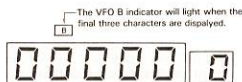

- Key in the final three characters (Six digits) of your call sign. For example, key in 6, 8, 7, 4, 8, 9.

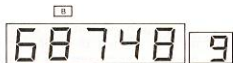

- When the final three characters have been keyed in, a long beep will sound and the display will be switched back to the digital access code display.



- If the RESET key is now pressed, the display will advance to the first three characters of the call sign, then if the key is depressed again to the final three characters, and if pressed again back to the digital access code display. Check to see that the call sign has been keyed in correctly.

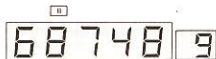

4-8. VOICE SYNTHESIZER

When the optional VS-1 Voice Synthesizer unit is installed and you press the VOICE key, the data in the frequency display will be audibly announced.

A. Frequency display

(a) VFO A, SSB



(b) “-” shift, TONE ON in memory channel with MR operating



(c) Nothing stored in memory with MR operating



B. Digital code display

For digital code channel 2



C. Call sign display

WD6DJY in memory

First characters (“A” light ON)



Final characters (“B” light ON)



D. Tone frequency display (For TR-851A/751A)

(Only figures are displayed.)



4-9. MICROPHONE UP/DWN SWITCH

The microphone UP/DWN switches are capable of performing two functions. These switches can also be used to alternate between MR and VFO modes or

to initiate channel linkage. The chart below describes how to use those function.

Operation		Function	
		UP switch	DWN switch
A	Press the FUNC and then the 5 key.	The UP switch will move the frequency up. (Normal operation)	The DWN switch will move the frequency down. (Normal operation)
B	Press the FUNC and then the 0 key.	The UP switch will now allow you to alternate between the VFO and MR mode.	The DWN switch now functions just like the CHL key on the front panel. (See Section 4-7-3.)

Note: _____
When the transceiver is delivered from the factory or when the microprocessor is reset, the UP/DWN switches function as normal frequency UP/DWN controls.

5. MAINTENANCE AND ADJUSTMENT

5-1. GENERAL INFORMATION

Your transceiver has been factory aligned and tested to specification before shipment. Under normal circumstances the transceiver will operate in accordance with these operating instructions. All adjustable trimmers and coils in your transceiver were preset at the factory and should only be readjusted by a qualified technician with proper test equipment. Attempting service or alignment without factory authorization can void the transceiver's warranty.

When operated properly, the transceiver can give years of service without requiring realignment. The information in this section gives some general service procedures which can be accomplished without sophisticated test equipment.

5-2. SERVICE

Should it ever become necessary to return the equipment to your dealer or service center for repair, pack in its original box and packing, and include a full description of the problems involved. Also include your telephone number. You need not return accessory items unless directly related to the service problem.

You may return your radio for service to the Authorized KENWOOD Dealer from whom you purchased it. A copy of the service report will be returned with the unit. Please do not send sub-assemblies or printed circuit boards. Send the complete unit, in its original boxes and packing.

Tag all returned items with your name and call for identification. Please mention the model and serial number of your radio in any correspondence, whether phone or written. For future reference, record this information in the space provided on the back cover of this manual.

5-4. IN CASE OF DIFFICULTY

Receive

Symptom	Probable cause	Action
Indicator does not light and data is not displayed when power switch is pressed.	1. Wrong power polarity. 2. Fuse is blown.	1. Connect red to "+" and black to "-". 2. Replace with the specified fuse. (See page 6 or 14.).
Display is dark.	Power voltage is low.	Chek voltage for 13.8 V DC \pm 15%.
No sound from the speaker. No signal can be received.	1. AF control is turned too far counterclockwise. 2. Squelch is closed. 3. PTT switch of microphone is pressed setting the unit in the transmit mode. 4. RF GAIN knob is turned too far counterclockwise. 5. Code squelch is operating.	1. Turn the VOL knob. 2. Turn the SQL knob counterclockwise. 3. Turn PTT switch off. 4. Turn RF GAIN knob fully clockwise. 5. Press C.SQ switch to clear code squelch.

Service note: _____

Dear OM, if you desire to correspond on a technical or operational problem, please make your note short, complete, and to the point. And PLEASE make it readable.

Please list: Model and serial number.

The question or problem you are having. Please give sufficient detail to diagnose: other equipment in the station, meter readings and anything you feel might be useful in attempting diagnosis.

Caution: _____

Do not pack the equipment in crushed newspapers for shipment! Extensive damage may result, during shipping.

Notes: _____

1. Record the date of purchase, serial number and dealer from whom purchased.
2. For your own information, retain a written record of any maintenance performed on the unit.
3. When claiming warranty service, please include a photocopy of the bill of sale, or other proof of purchase showing the date of sale.

5-3. CLEANING

The knobs, front panel and cabinet of the transceiver are likely to become soiled after extended use. The knobs should be removed from the transceiver and cleaned with a neutral soap and warm water. Use a neutral soap (not harsh chemicals) and damp cloth to clean the cabinet and front panel.

Symptom	Probable cause	Action
Sensitivity is low.	RF GAIN knob is turned too far counterclockwise.	Turn RF GAIN knob fully clockwise.
Signal is being received but no sound is heard.	Wrong mode.	Enter another mode.
No control works.	LOCK is ON.	Press FUNC, F.LOCK keys.
TUNING control does not alter frequency in display. (With the TR-851A/751A)	COM switch is ON.	Press COM, MR, or A/B key.
Beep does not stop after a numeric key is pressed.	Memory write operation is ON. The unit is waiting for entry of split memory transmit frequency.	Press numeric key 9 or 0.
When "--.---.---" is displayed after M key is pressed, no control works.	Nothing is stored in the memory channel.	Press A/B key to set VFO mode.
Frequency display is zero.	DCL digital code set mode or call sign set mode is ON.	Press CS key.
The microphone UP/DOWN switch will not increase or decrease the memory channel or displayed frequency. (The switches select VFO or MR, and initiate channel linkage.)	FUNC and 0 keys are pressed.	Press FUNC and 5 keys.
Memory cannot be backed up.	Backup battery voltage is low.	See Section 5-5.

Transmit

Symptom	Probable cause	Action
Output	1. Microphone jack is not plugged in. 2. Poor antenna connection.	1. Plug jack in. 2. Connect antenna securely.
In CW, pressing the key does not cause transmission.	1. Key jack is not plugged in. 2. Poor key contact.	1. Plug jack in. 2. Clean contact.
In USB, LSB, or CW, the called station does not answer.	RIT causes send and receive frequency mismatch.	Press RIT switch to exit RIT mode.

5-5. MICROPROCESSOR BACK-UP LITHIUM BATTERY REPLACEMENT

Lithium battery replacement should be performed by an authorized KENWOOD service facility; either your KENWOOD dealer, or the factory, since this unit contains CMOS type circuitry.

Notes:

- When the lithium battery is replaced, the microprocessor must be reset, using the procedure in Section 4-4-2.
- When the lithium battery fails, the radio's microcoded functions are not affected. Only information stored in memory will be created.

5-6. ORDERING SPARE PARTS

When ordering replacement or spare parts for your equipment, be sure to specify the following: Model and serial number of your transceiver. Schematic number of the part. Printed circuit board number on which the part is located, part number and name, if known, and quantity desired. Part numbers for most replacement parts is contained in the service manual (available as an option from your dealer).

5-7. ADJUSTMENTS

5-7-1. Cover removal

Remove four screws to detach each cover as shown. The bottom cover has the speaker attached. Be careful in handling the bottom cover. When

A. Top cover

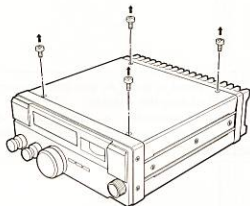

attaching the cover, be sure not to let the wiring be caught between the covers and chassis. Be sure to plug in the speaker connector on the bottom cover.

B. Bottom cover

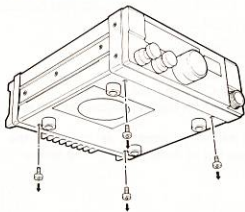

5-7-2. Opening the front panel

1. Loosen two screws (A) and remove the two screws (B) as shown.
2. Pull the panel toward you and rotate it down as shown.

Be careful of the wiring.

3. To close the panel, align it with the embossing (C) shown in Figure below. Push the panel. Fasten the two screws at (A) and (B). Take care not to pinch any wiring.

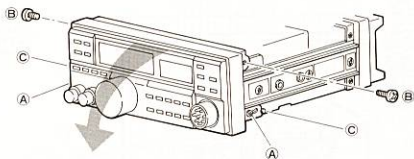

5-7-3. Low power output

Turn VR3 during low-power transmission to adjust the power output in a range of about 2 to 25 watts.

5-7-4. Semi break-in delay time

In the CW mode, turn VR7 for the desired delay time.

5-7-5. Sidetone level

Turn VR6 while holding down the key in the USB, LSB, or CW mode for the desired tone level.

5-7-6. Scan operation mode selection

A. CO (Carrier Operated) scan

TO (Time Operated) scan can be changed to CO scan by cutting diode D17. When CO scan mode is selected the radio will remain on a station approximately 1.5 seconds after the carrier drops out, and then resume CO scan. (Refer to page 36)

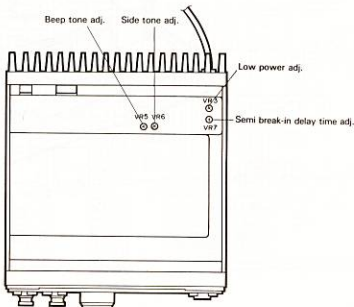

B. Open channel scan

Busy channel scan can be changed to open channel scan by cutting diode D18. When the open channel scan mode is selected the radio will remain on the open channel until a signal is received or 1.5 seconds has elapsed (Depends on whether you have selected TO or CO scan).

5-7-7. Frequency step selection for the open channel search. (TR-751A only)

Cut D14 to change channel steps from 15 kHz to 20 kHz in an open channel search operation.

5-7-8. Beep tone level

Turn VR5 to the desired tone volume.

5-7-9. Call sign monitor

(With the optional Call sign display CD-10)

On the CD-10, you can display the call sign of your station.

Connect TP8 (MONI) to point A as shown in the figure. Take care not to damage the nearby wiring.

Note:

When TP8 is wired to point A, you can monitor your control signal of thru the speaker.

However, this generates a slight noise during transmission. During operations, disconnect the wiring if possible.

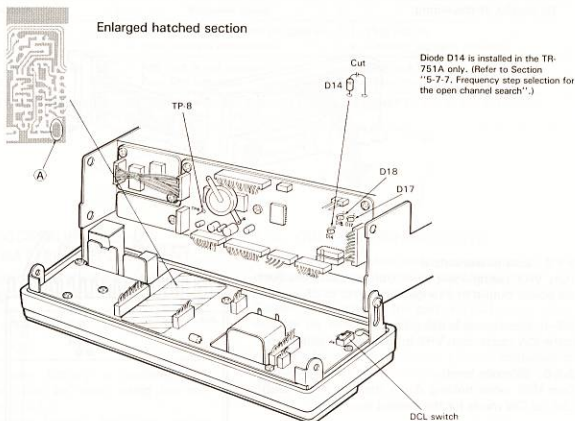

6-1-2. TR-751A/751E

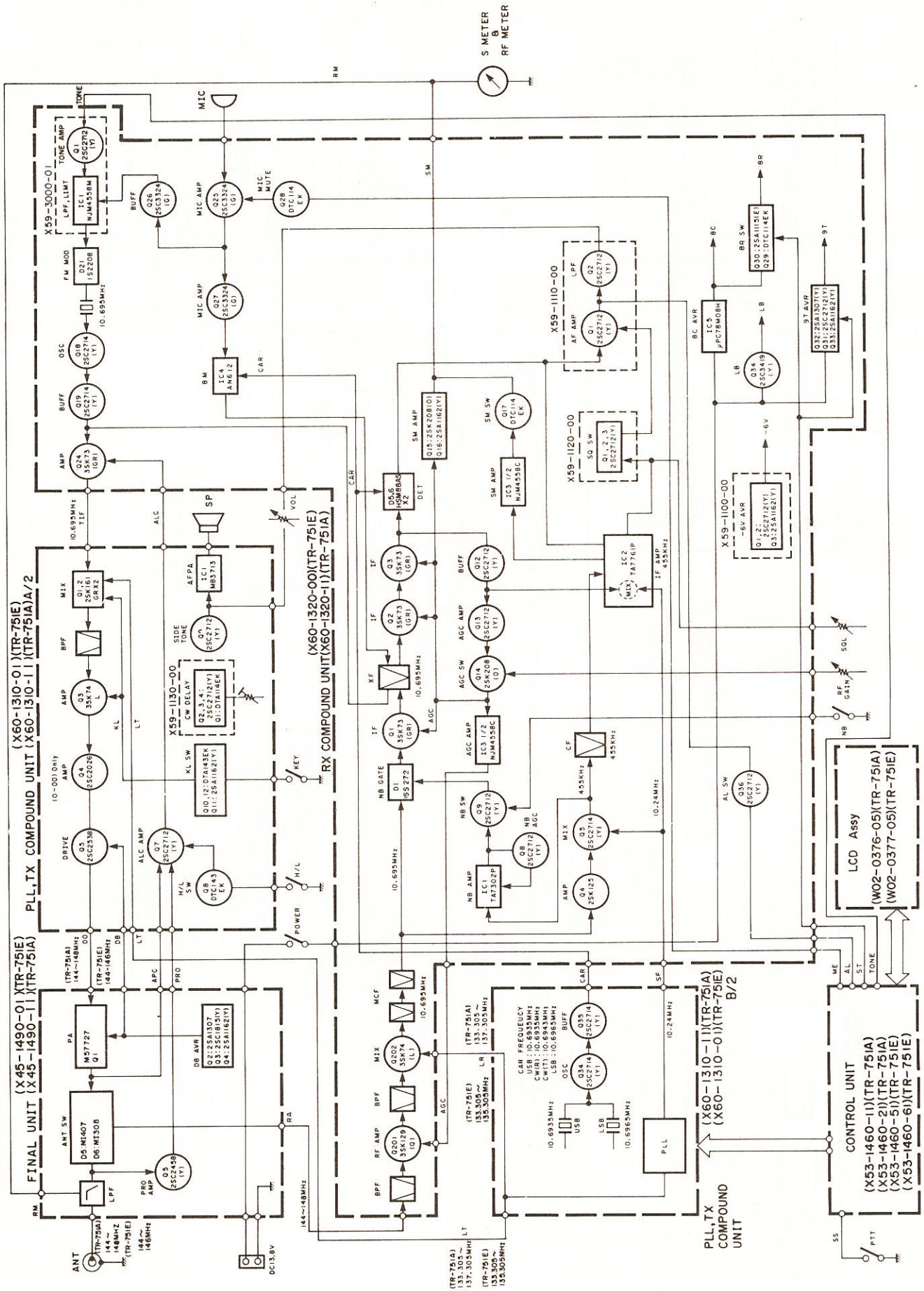

6-2. CIRCUIT DIAGRAM

6-2-1. TR-851A/851E

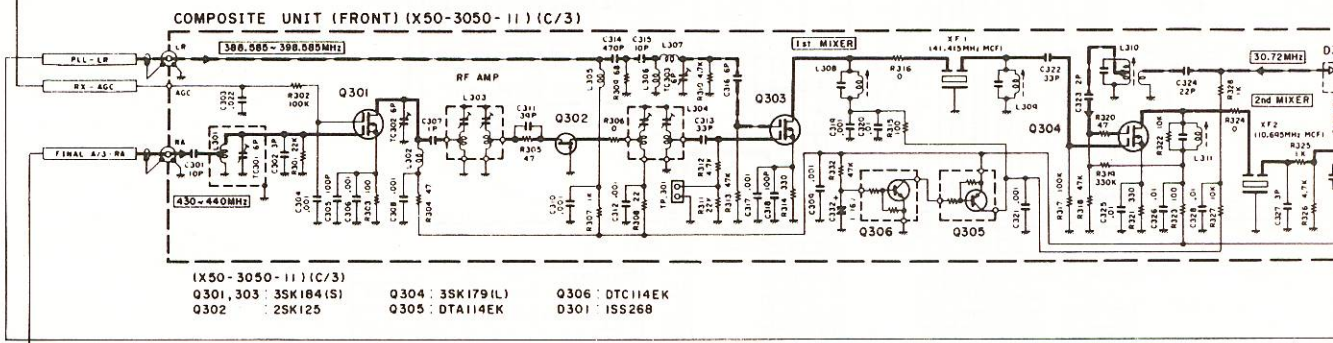
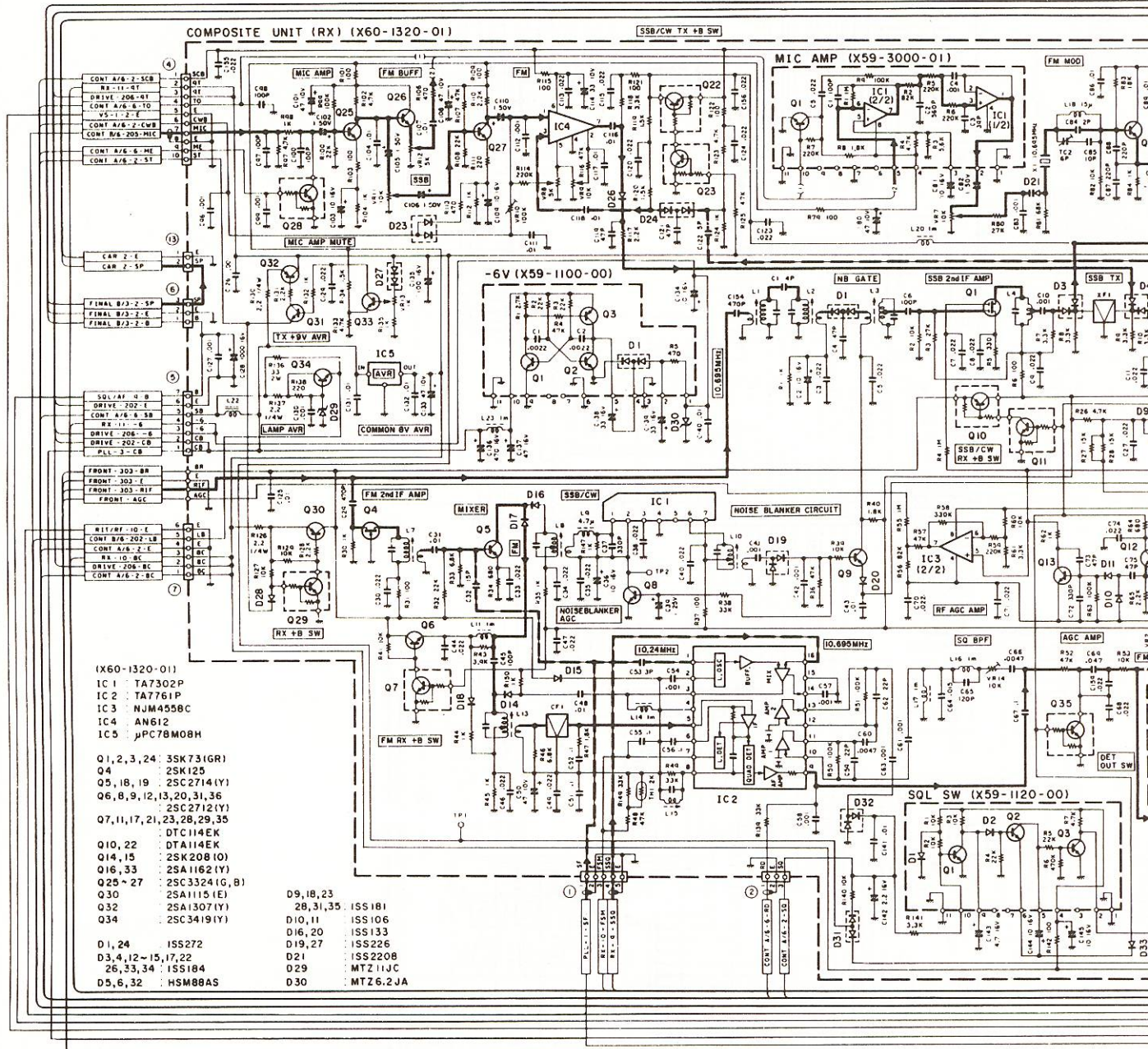

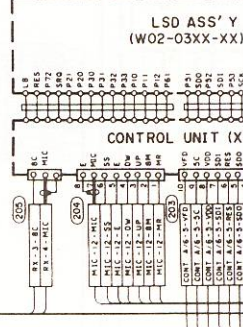
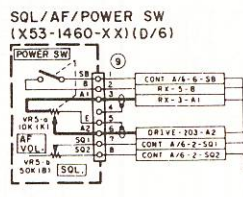
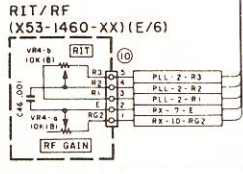
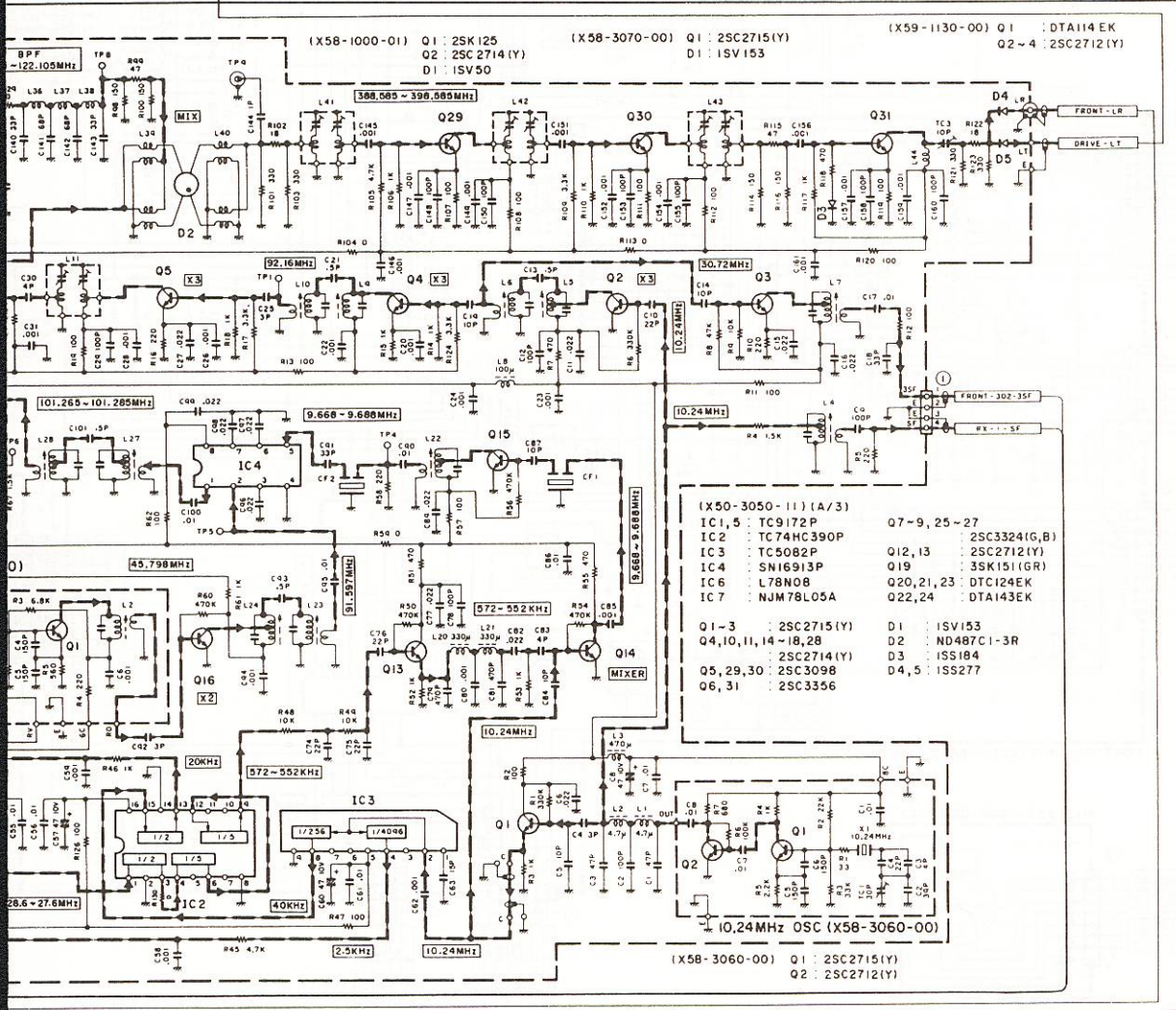
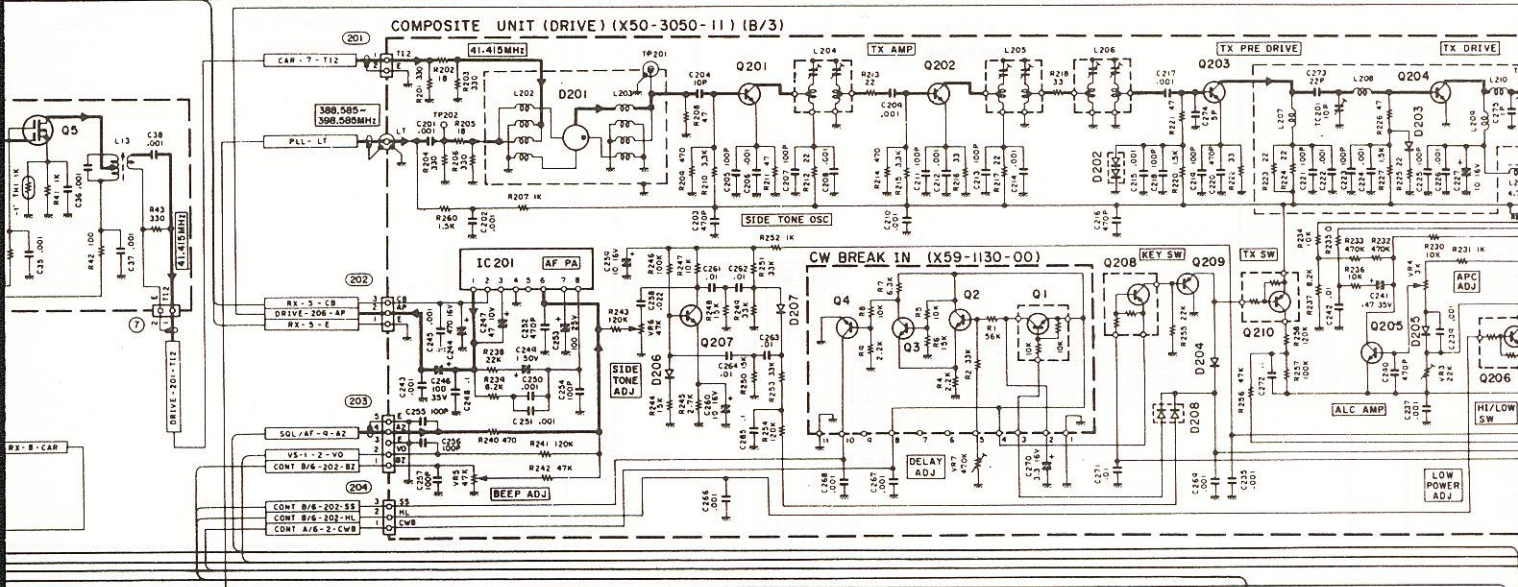

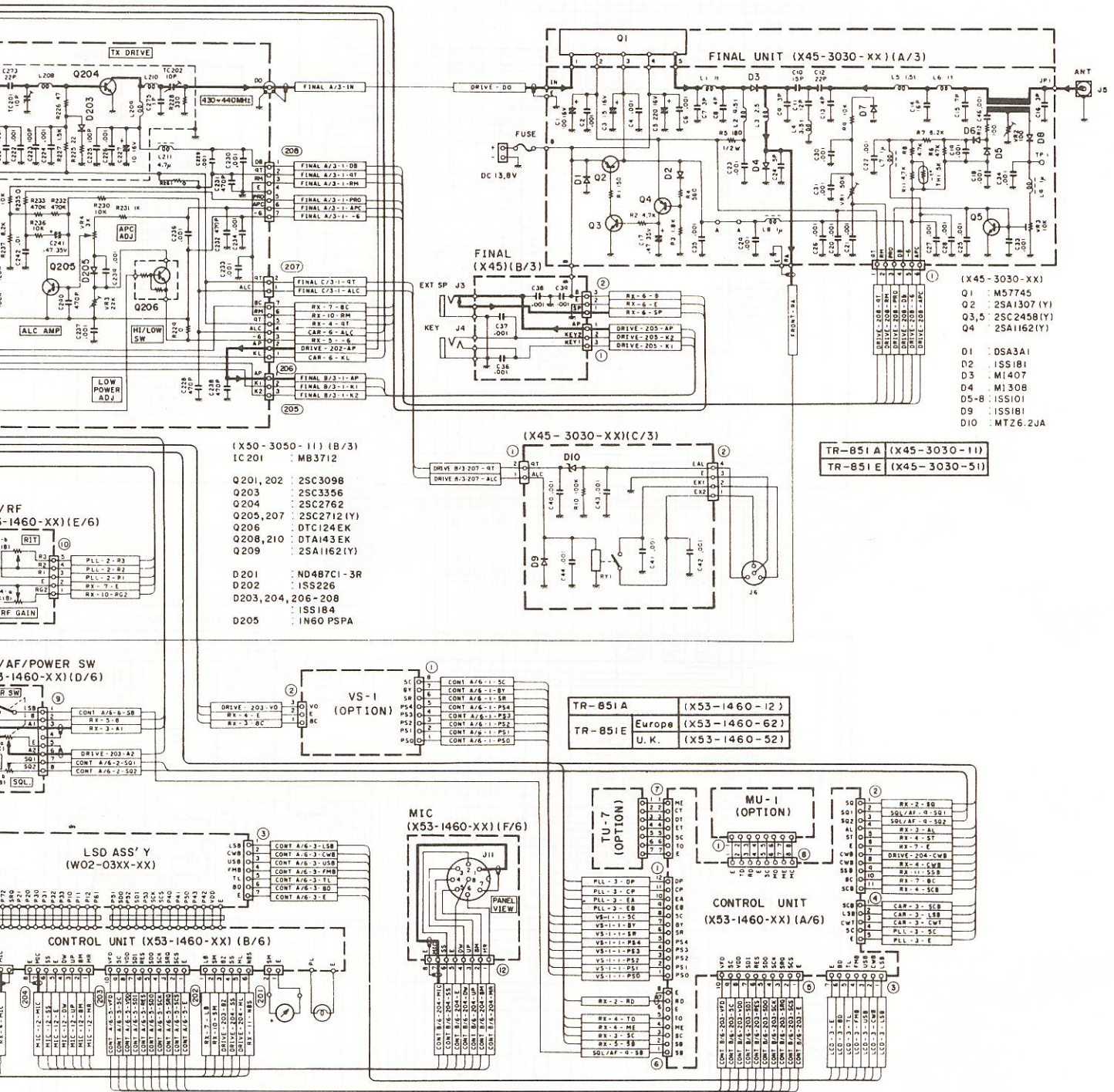

TR-851A/851E (1/2)

Note:
 Circuit is subject to change without notice due to advancements in technology.

Q301	R301-303	LCD ASS'Y
YES	YES	B160B
NO	NO	B160C
NO	NO	B160D

LCD SHIFT PRINT
-,+
D-A,D-B
-,+

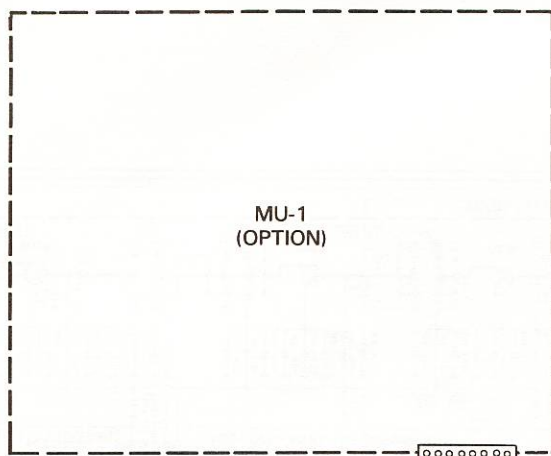

- Q4,6,20~203,301,302
 Q5 : DTC114EK
 Q7,8 : DTA114TK
 : DTA114EK
- IC1 : μ P0750BHG-564-22
 IC2 : DT5C124E
 IC3 : DT5A143E
 IC4 : μ P075075CT-226
 IC5 : NJM2930L-06
 IC6 : NE555P
- IC201 : BU45B4B
 IC202 : P57523C
 IC301 : μ P07514G-143-12
- D1~9,11,14,16~18,22~24,207~211
 : 1S5133
 D19,20,25,26,30,31,33
 : 1S5184 or DAN202K
 D21,27,201~206
 : 1S5181 or DAP202K
 D29 : 1S5106
 D22 : LN322GP
 D213 : LN422VP
 D301,306 : MP-2A00D1
 D302,308 : MP-1BR00D1
 D301~307,307
 : MP-2B00D1

PTION)

MU-1
(OPTION)

TU-7
(OPTION)
TR-851A only

TR-851A	NO.	D1	D3	D4	D5	D6	D8	D14	D30
(X53-1460-12)		NO	YES	NO	NO	NO	NO	YES	NO
Europe (X53-1460-62)		YES	NO	YES	YES	YES	YES	NO	YES
U. K. (X53-1460-52)		YES	NO	NO	NO	YES	YES	NO	YES

B	C	H	JR2	JR5	J7
NO	YES	NO	NO	NO	YES
YES	NO	NO	YES	YES	NO
YES	NO	YES	YES	NO	NO

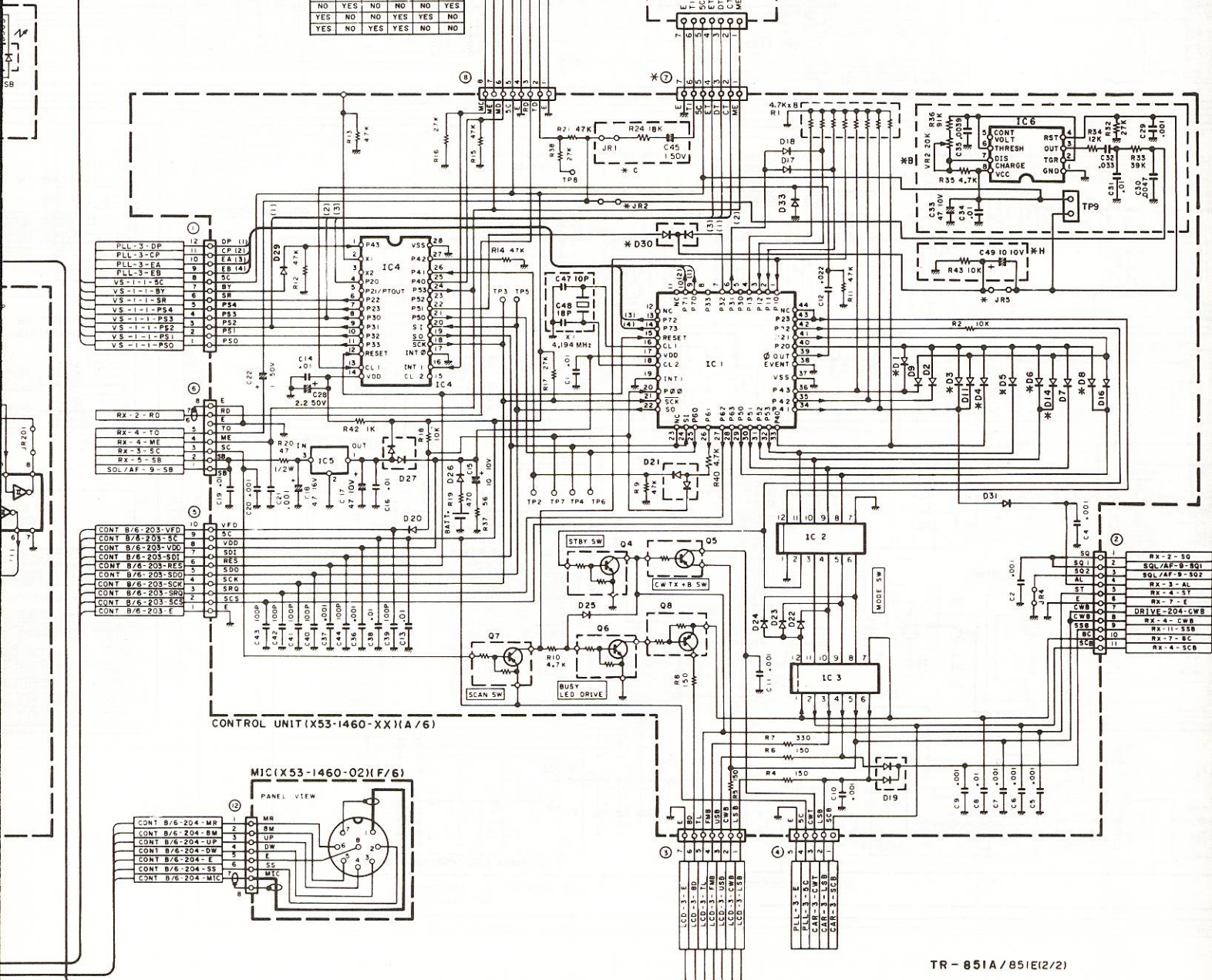

CONTROL UNIT (X53-1460-XX)(A/F/6)

MIC (X53-1460-02)(F/6)

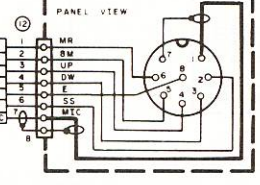

TR-851A/851E(2/2)

Note:
Circuit is subject to change without notice due to advancements in technology.

22

- D1~9, 11, 14, 16~18, 22~24, 207~211
ISS 133
- D19, 20, 25, 26, 30, 31, 33
ISS 184 or DAN 202K
- D21, 27, 201~206
ISS 181 or DAP 202K
- D29
ISS 106
- D27
LN 322GP
- D213
LN 422+P
- D301, 306
MP-24A 001
- D302, 308
MP-1BR 001
- D303, 305, 307
MP-2BG 001

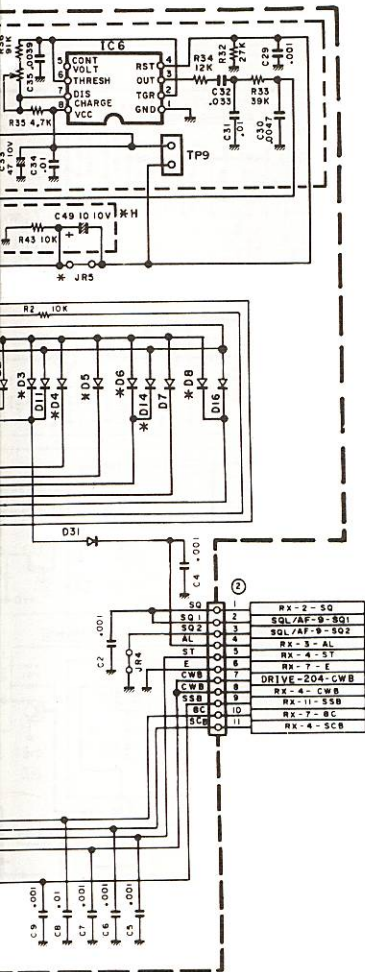

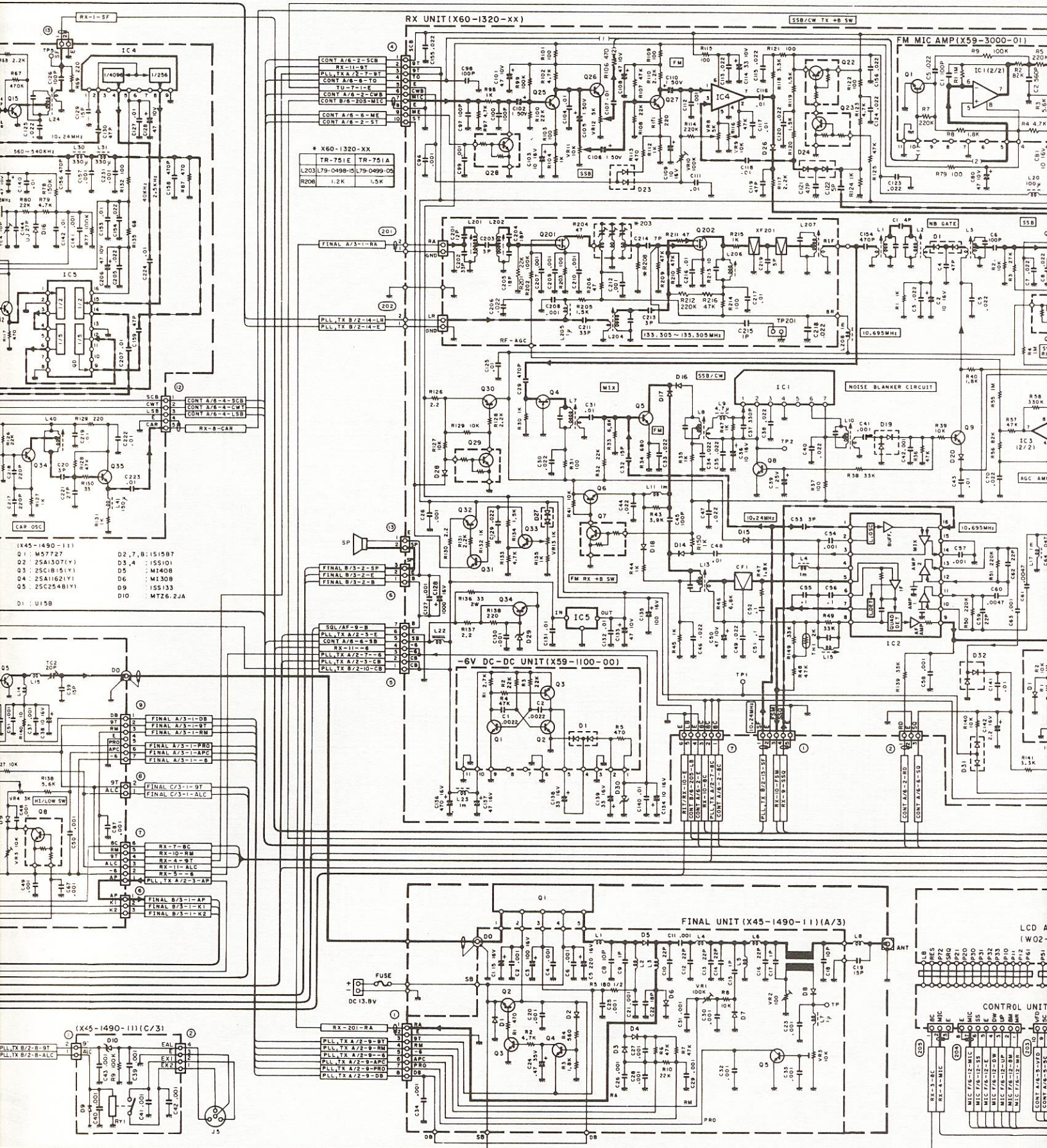

Note:
Circuit is subje

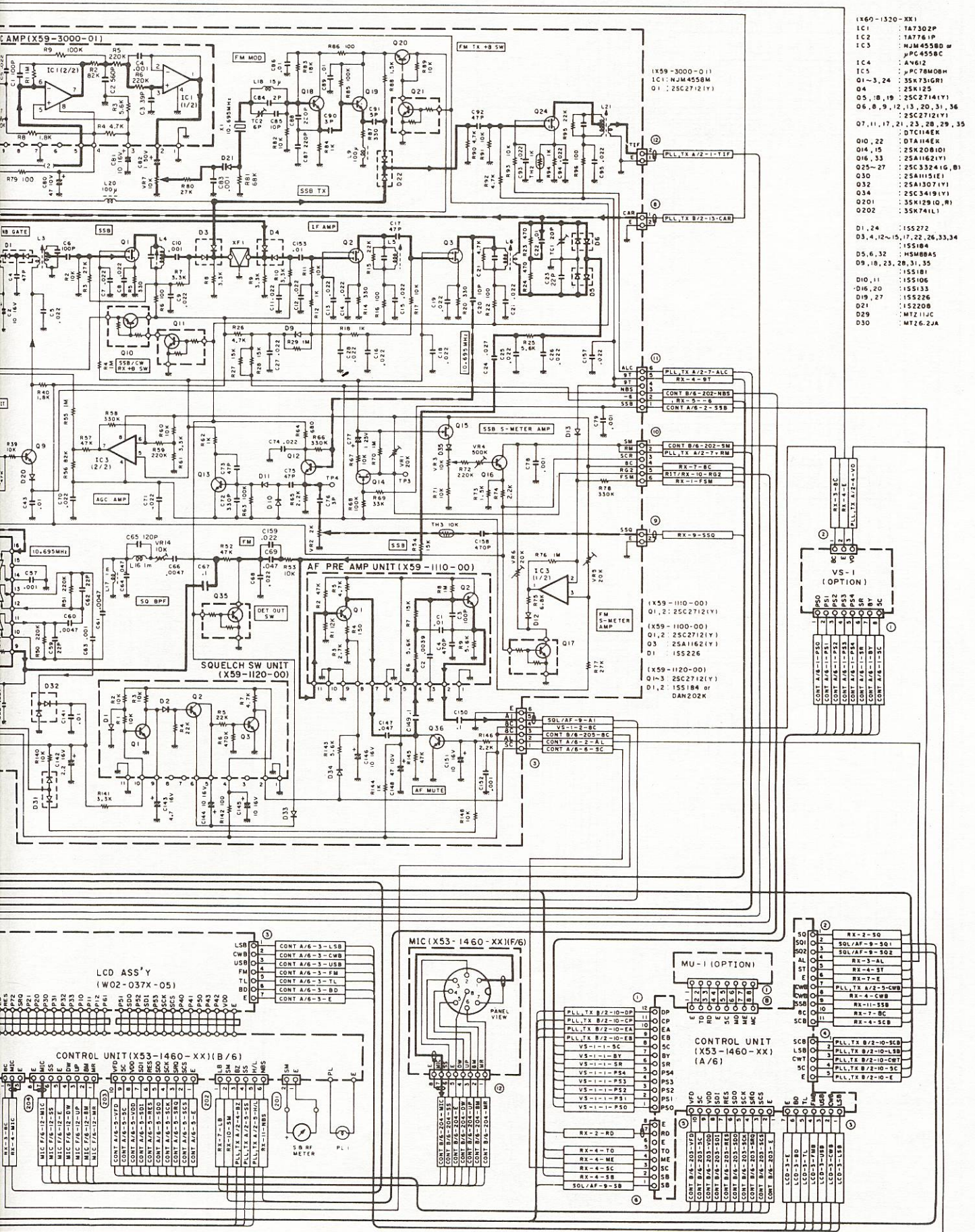

- (X60-1320-XX)
- IC1 : TA7302P
 - IC2 : TA7761P
 - IC3 : NJM4558B w/PC4558C
 - IC4 : AV612
 - IC5 : PC78M08H
 - Q1-3,24 : 5K731GRI
 - Q4 : 2SK125
 - Q5,18,19 : 2SC2714(Y)
 - Q6,8,9,12,13,20,31,36 : 2SC2712(Y)
 - Q7,11,17,21,23,28,29,33,35 : DT144EX
 - Q10,22 : DT144EX
 - Q14,15 : 2SK2081(D)
 - Q16,33 : 2SA1621(Y)
 - Q25-27 : 2SC3324(G,B)
 - Q30 : 2SA1115(E)
 - Q32 : 2SA1507(Y)
 - Q34 : 2SC3419(Y)
 - Q201 : 5SK128(D,R)
 - Q202 : 5SK741(L)
- D1,24 : 1S5272
- D3,4,12-15,17,22,26,33,34 : 1S5184
- D5,6,32 : MSMB8AS
- D9,18,23,28,31,35 : 1S5181
- D10,11 : 1S5106
- D16,20 : 1S5133
- D19,27 : 1S5226
- D21 : 1S5208
- D29 : MTZ11JC
- D30 : MTZ262A

TR-751A
TR-751E

Note: Circuit is subject to change without notice due to advancements in technology.

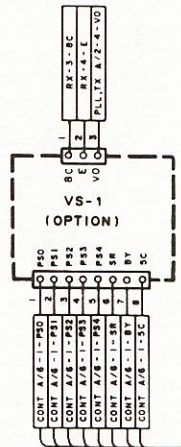
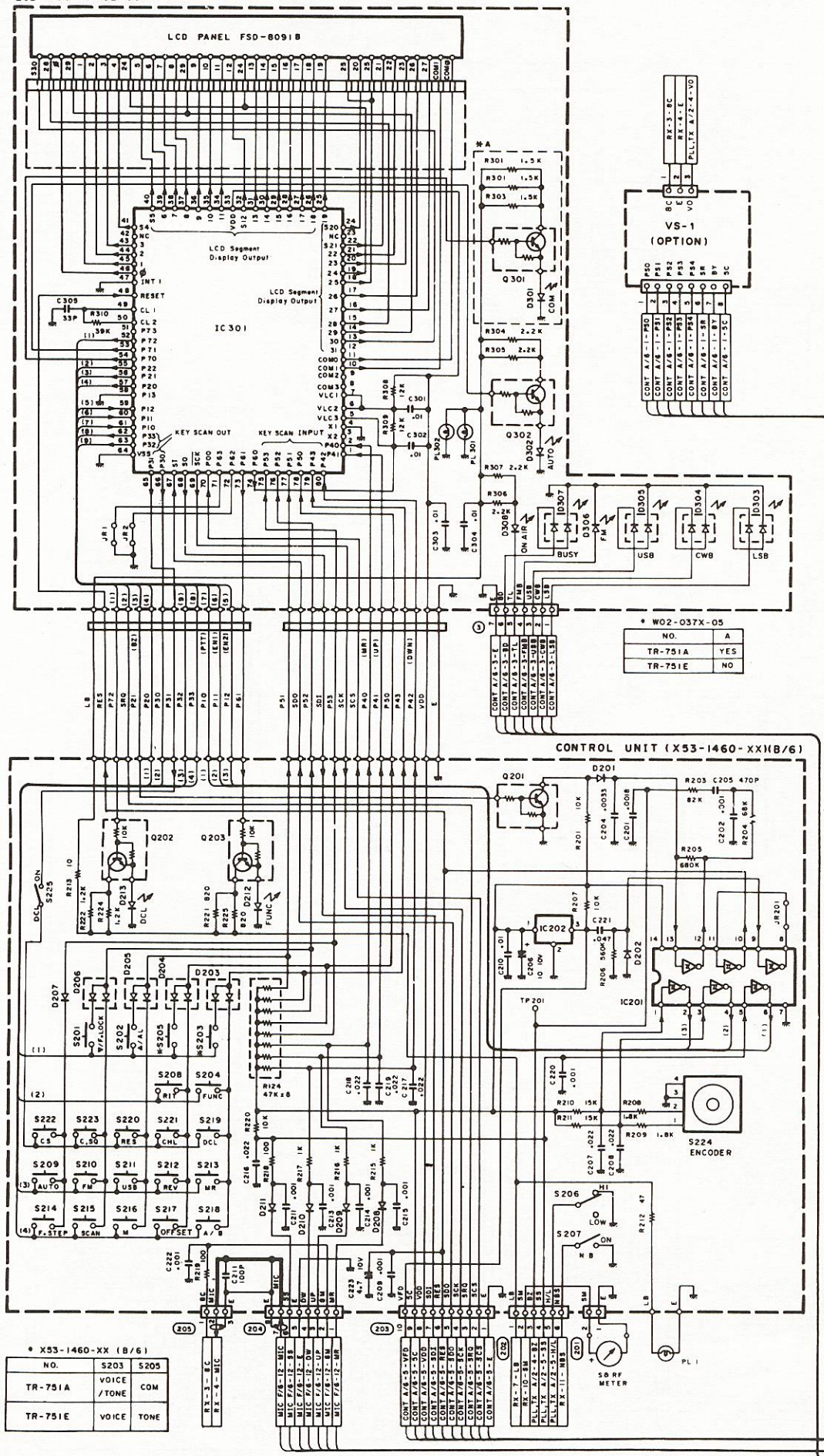

* W02-037X-05	
NO.	A
TR-751A	YES
TR-751E	NO

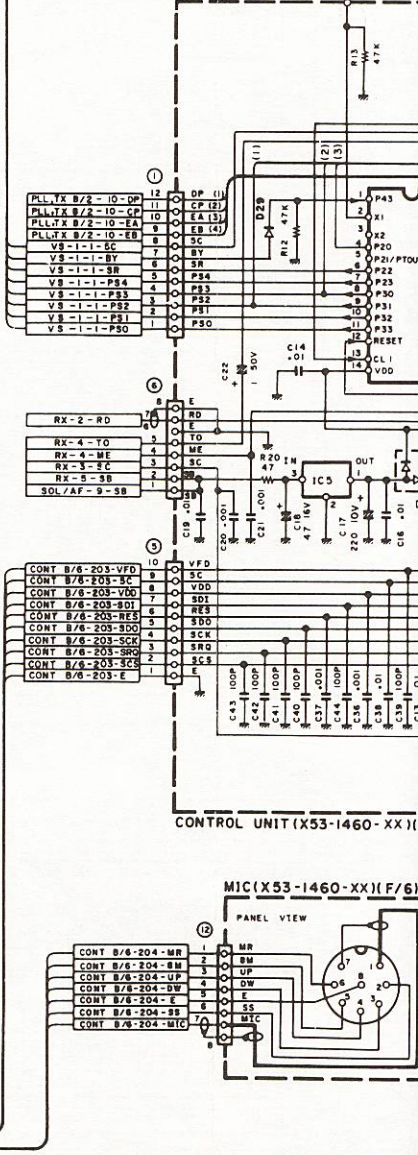

- 01,2,4,6,201~203,301,302
 03 DTC114EK
 05 2SC2712(Y)
 05 DTA114TK
 07,8 DTA114EK
- IC1 μ PD7508HG-545-22
 IC2 DT5C124E
 IC3 DT5A143E
 IC4 μ PD7507SCT-215
 IC5 M5278L56
 IC6 NE555P
- IC201 BU4584B
 IC202 PST523C
 IC301 μ PD7514G-143-12
- D1~8,11,12,14,16~18,22~24,207~211
 1SS133
 D19,20,25,26,30,31,
 1SS184 or DAN 202K
 D21,27,201~206
 1SS181 or DAP 202K
 D29 1SS106
 D212 LN3220P
 D213 LN422YP
 D301,306 MP-2AA001
 D302,308 MP-1BR001
 D303~305,307
 MP-28G001

* X53-1460-XX (A/6)

NO.	D3	D4	D5	D6	D7	D14	D30	A	B
TR-751A	U.S.A. Version	YES	YES	NO	NO	NO	YES	NO	NO
	Other market Version	YES	NO	NO	NO	NO	YES	NO	YES
TR-751E	U.K. Version	NO	NO	NO	YES	YES	NO	YES	NO
	Europe Version	NO	YES	YES	YES	NO	YES	NO	YES

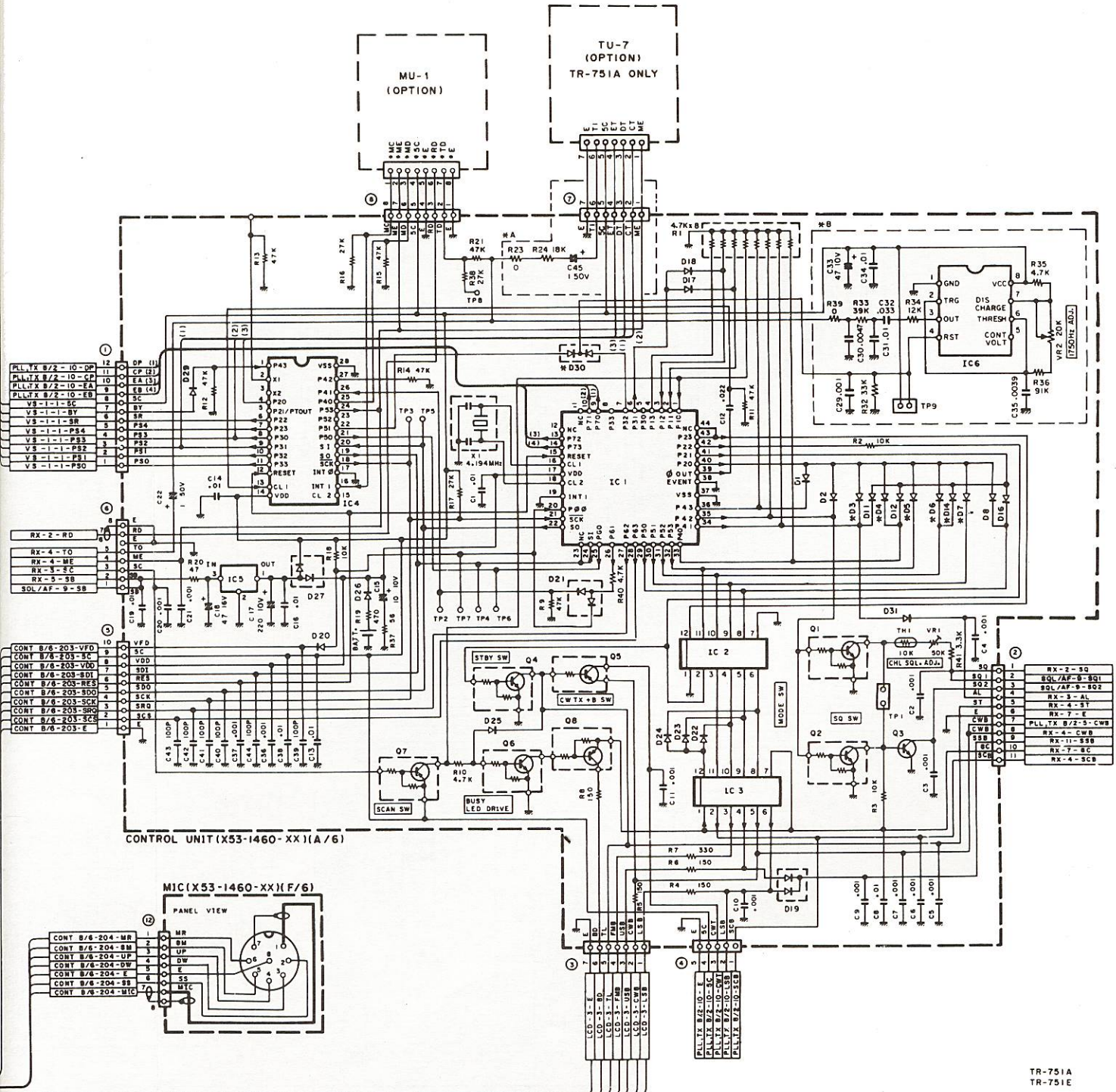

TR-751A
 TR-751E

Note: _____
 Circuit is subject to change without notice due to advancements in technology.

7. OPTIONAL ACCESSORIES

7-1. MU-1 MODEM UNIT

Installing the MU-1 Modem unit.

Remove the top and bottom covers. Open the panel. (See page 35.)

Install the Modem unit in the upper left corner of the Control unit on the main chassis side with the two furnished screws as shown. After the MU-1 is installed turn the DCL switch on to activate the DCL system. (See the figure on page 36, for the location of the switch.)

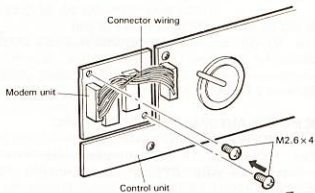

7-2. TU-7 TONE UNIT

Installing the TU-7 Tone unit.

Remove the top and bottom covers. Open the panel. (See page 35.)

Install the Tone unit in the upper left corner of the Control unit on the main chassis side with the furnished screw as shown.

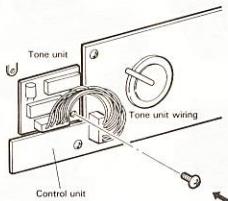

7-3. TU-7 TONE UNIT AND MU-1 MODEM UNIT

Installing the MU-1 Modem unit and TU-7 Tone unit. Install the Tone unit on top of the Modem unit shown below. Fix the Modem unit to the Control unit with a screw at the upper left and the furnished hexagonal boss at the lower right. Attach the furnished cushion on the Tone unit. Install the Tone unit on the hexagonal boss on the Modem unit with a screw. Connect the Modem unit after the physical installation has been completed.)

After the MU-1 is installed turn the DCL switch on to activate the DCL system. (See the figure on page 36 for the location of the switch.)

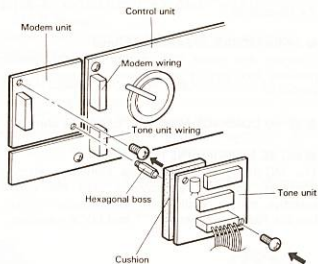

7-4. VS-1 VOICE SYNTHESIZER UNIT

Installing the VS-1 Voice Synthesizer unit

Remove the bottom cover. Install the VS-1 voice synthesizer unit on the tongues at the front left side of the RX unit with two screws as shown. Run the wires inside.

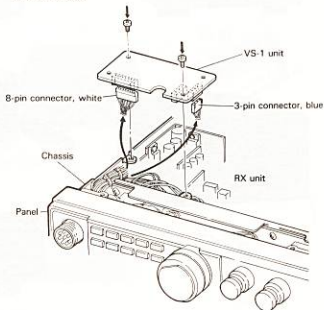

7-5. OTHER ACCESSORIES

■ PS-50 HEAVY DUTY DC POWER SUPPLY

May be used with the TR-851A/851E/751A/751E for stable operation.

■ PS-430 DC POWER SUPPLY

May be used with the TR-851A/851E/751A/751E for stable operation.

■ KPS-7A DC POWER SUPPLY (U.S.A. only)

May be used with the TR-751A

■ SP-430 EXTERNAL SPEAKER

The SP-430 is an attractive, compact external speaker. This low-distortion speaker provides clear reproduction of the high-quality audio obtained from the transceiver.

■ SP-50 MOBILE SPEAKER (8 ohms)

Compact and smart high quality external speaker provides flexibility of installation for maximum convenience.

■ SP-40 COMPACT MOBILE SPEAKER (4 ohms)

■ MC-85 MICROPHONE (8-pin)

The MC-85 is a unidirectional high-class electret condenser microphone provided with the output selective switch, audio level compensation circuit, low cut filter, level meter, PTT and LOCK switches.

■ MC-80 MICROPHONE (8-pin)

The MC-80 is an omnidirectional electret condenser microphone provided with UP/DOWN switches, volume adjustment for output level, PTT and LOCK switches, built-in pre-amplifier.

■ MC-60A MICROPHONE (8-pin)

The zinc die-cast base provides high stability, and the MC-60A is complete with PTT and LOCK switches, UP/DOWN switches, and impedance selector switch and a built-in pre-amplifier.

■ MC-55 MOBILE MICROPHONE (8-pin)

The MC-55 provides UP/DOWN switches, LED display for switching transmit or receive, adjustable microphone gain, automatic receive returning circuit (approx. 5 minutes) and many functions.

■ MC-48B AUTOPATCH UP/DOWN HAND MICROPHONE (8-pin)

The MC-48 is 16-key autopatch UP/DOWN microphones with PTT switch. Encodes 16 autopatch tones. UP/DOWN switches provide step frequency change, or initiate band scan in the appropriate direction, if held depressed momentarily.

■ MC-42S UP/DOWN HAND MICROPHONE

The MC-42S is handy dynamic microphone with PTT switch and UP/DOWN switches.



PS-50



SP-430



MC-80



PS-430



SP-50



MC-60A



SP-40



MC-55

■ MB-10 MOBILE MOUNT

The mobile mount MB-10 allows easy installation and removal of the TR-851A/851E/751A/751E.

■ CD-10 CALL SIGN DISPLAY

The CD-10 stores the call sign of the calling station in its memory and displays it on an LCD display. Call signs of up to 20 of the most recently calling stations are stored. Allowing the operator to quickly check for and return any call.

■ AC-10 AC ADAPTER FOR CD-10

■ PG-2N DC POWER CABLE

■ PG-3B DC LINE NOISE FILTER

May be used with the TR-851A/851E/751A/751E to suppress ignition noise.

■ SW-200A/200B SWR/POWER METER (supplied with a coupler)

SW-200A supplied with SWC-1. SW-200B supplied with SWC-2. Selectable peak-leading/RMS. SWR/POWER meters cover 1.8 ~ 150 MHz (SW-200A), 140 ~ 450 MHz (SW-200B) in range of 0 ~ 20/200W, full scale for base station use.

■ SW-100A/100B SWR/POWER METER

Compact and lightweight SWR/POWER/VOLT meters cover 1.8 ~ 150 MHz (SW-100A), 140 ~ 450 MHz (SW-100B) in range of 150W full scale for mobile use.

■ SWT-1/SWT-2 ANTENNA TUNING UNIT

The SWT-1 (2m band) and the SWT-2 (70 cm band) are an antenna tuning unit designed for use in conjunction with an SWR/POWER meter to allow efficient transmission. This unit is especially convenient for monitoring SWR, using a KENWOOD SWR/POWER meter.

■ HS-7 MICRO HEADPHONES (16 ohms)

■ HS-6 COMMUNICATIONS HEADPHONES (12.5 ohms)

Deluxe, very light-weight headphones designed for communications equipment.

■ HS-5 COMMUNICATIONS HEADPHONES (8 ohms)

Headphones designed for communications equipment. These light-weight open air-type headphones remain comfortable during extended operation. Easily attached earpads are provided.

■ HS-4 COMMUNICATIONS HEADPHONES (8 ohms)



MC-48



SWT-1/SWT-2



HS-5



MB-10



SW-100A/100B



HS-7



MC-42S



CD-10



SW-200A/200B



HS-6

8. REFERENCE

8-1. ANTENNA

8-1-1. Fixed station

Various types of fixed station antennas are commercially available. Select your antenna according to available space and intended application.

Transceiver performance depends largely on the

type of antenna used. For fixed station operation there are ground plane antennas (omnidirectional) and Yagi antennas (unidirectional). The Yagi antenna is suitable for DX (Long distance) operation or communication with a specific party.

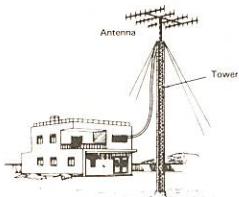
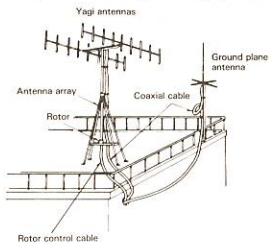

8-1-2. Mobile

Various types of antennas for UHF/VHF mobile operation are available. Please consult your dealer for information on these antennas.

Note:

For gutter-mount installation, the antenna bracket must be grounded to the car body as shown below. Attach the antenna securely, referring to the antenna installation instructions provided with the antenna.

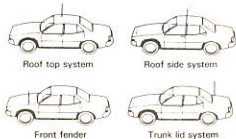

Installation for mobile operation

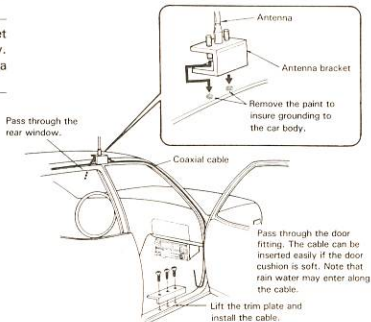

8-2. MOBILE INSTALLATION

8-2-1.Noise reduction

In motor vehicles, noise is generated by the ignition system. Other sources of noise include the wiper and heater motors.

Although the transceiver is equipped with a noise blanker to minimize ignition noise, it is imperative that some preventive measures be taken to reduce the noise to the lowest possible level.

(a) Antenna location selection

Since ignition noise is generated by the vehicles engine, the antenna must be installed as far from the engine as possible.

(b) Bonding

The component parts of motor vehicles, such as the engine, transmission, muffler system, accelerator, etc., are coupled to one another at DC and low frequencies, but are isolated at high frequencies. By connecting these parts using heavy, braided ground straps, ignition noise can be reduced. This connection is called bonding''.

(c) Use ignition suppressor cable or suppressor spark plugs

Noise can be reduced by using spark plugs with internal resistors, or resistive suppressor ignition cable.

8-2-2. Battery capacity

The power system of a motor vehicle is comprised of a battery and an alternator (which generates power while the engine is running) to supply current to loads or to charge the battery.

Since the transceiver draws high current during transmit, care should be exercised so the power system is not overloaded. When using the transceiver, the following points should be observed from the viewpoint of battery maintenance:

- (a) Turn the transceiver OFF when the lights, heater, wipers and other high-draw accessories are used.
- (b) Avoid transceiver operation when the engine is not running.
- (c) If necessary, use an ammeter and/or a voltmeter to check battery condition.

2.1.1.1.1.1.1

... ..

2.1.1.1.1.1.2

... ..

... ..

2.1.1.1.1.1.3

... ..

... ..

... ..

... ..

Model TR-851A/851E/751A/751E

Serial No. _____

Date of Purchase _____

Dealer _____

KENWOOD CORPORATION

Shionogi Shibuya Building, 17-5, 2-chome Shibuya, Shibuya-ku, Tokyo 150, Japan

TRIO-KENWOOD COMMUNICATIONS

Post Office Box 7065, Compton, California 90224, U.S.A.

KENWOOD COMMUNICATIONS

DIVISION OF KENWOOD ELECTRONICS DEUTSCHLAND GMBH

Rembrücker Str. 15, 6056 Heusenstamm, West Germany

KENWOOD ELECTRONICS BENELUX N.V.

Leuvensesteenweg 504, B-1930 Zaventem, Belgium

KENWOOD ELECTRONICS AUSTRALIA PTY. LTD.

4E Woodcock Place, Lane Cove, N.S.W. 2066, Australia

KENWOOD